

**REDACTED**

**UNITED STATES DISTRICT COURT  
EASTERN DISTRICT OF MICHIGAN  
SOUTHERN DIVISION**

\_\_\_\_\_)  
)  
)  
In Re: AUTOMOTIVE PARTS ) 12-md-02311  
ANTITRUST LITIGATION ) Honorable Marianne O. Battani  
\_\_\_\_\_)  
) 2:13-cv-02203-MOB-MKM  
In re: FUEL INJECTION SYSTEMS )  
\_\_\_\_\_) CORRECTED CONSOLIDATED AMENDED  
) CLASS ACTION COMPLAINT  
THIS RELATES TO: )  
) JURY TRIAL DEMANDED  
ALL END-PAYOR ACTIONS )  
) **[REDACTED]**  
\_\_\_\_\_)

**REDACTED**

Plaintiffs Ifeoma Adams, Halley Ascher, Gregory Asken, Melissa Barron, Kimberly Bennett, David Bernstein, Ron Blau, Tenisha Burgos, Kent Busek, Jennifer Chase, Rita Cornish, Nathan Croom, Lori Curtis, Jessica Decastro, Alena Farrell, Jane Fitzgerald, Carroll Gibbs, Dori Gilels, Jason Grala, Ian Groves, Curtis Gunnerson, Paul Gustafson, Tom Halverson, Curtis Harr, Andrew Hedlund, Gary Arthur Herr, John Hollingsworth, Leonard Julian, Carol Ann Kashishian, Elizabeth Kaufman, Robert Klingler, Kelly Klosterman, James Marean, Michelle McGinn, Nilsa Mercado, Rebecca Lynn Morrow, Edward Muscara, Stacey Nickell, Sophie O’Keefe-Zelman, Roger Olson, Susan Olson, William Picotte, Whitney Porter, Cindy Prince, Janne Rice, Robert Rice, Jr., Frances Gammell-Roach, Darrel Senior, Meetesh Shah, Darcy Sherman, Erica Shoaf, Arthur Stukey, Kathleen Tawney, Jane Taylor, Keith Uehara, Michael Wick, Thomas Wilson, and Phillip Young (“Plaintiffs”), on behalf of themselves and all others similarly situated (the “Classes” as defined below), upon personal knowledge as to the facts pertaining to themselves and upon information and belief as to all other matters, and based on the investigation of counsel, bring this class action for damages, injunctive relief, and other relief pursuant to federal antitrust laws and state antitrust, unfair competition, consumer protection, and unjust enrichment laws, and allege as follows:

**NATURE OF ACTION**

1. This lawsuit is brought as a proposed class action against Defendants Aisan Industry Co., Ltd., Franklin Precision Industry, Inc., Aisan Corporation of America, Hyundam Industrial Co., Ltd., (collectively, “Aisan Defendants” or “Aisan”), DENSO Corporation, DENSO International America, Inc., DENSO Internation Korea Corporation (“DIKR”) (collectively, “DENSO Defendants” or “DENSO”), Hitachi Automotive Systems, Ltd., Hitachi

**REDACTED**

Automotive Systems Americas, Inc. (together, “Hitachi Defendants” or “Hitachi”),<sup>1</sup> Keihin Corporation, Keihin North America, Inc. (together, “Keihin Defendants” or “Keihin”), Maruyasu Industries Co., Ltd. (“Maruyasu”), Mikuni Corporation, Mikuni American Corporation (together, “Mikuni Defendants” or “Mikuni”), Mitsuba Corporation, American Mitsuba Corporation (together, “Mitsuba Defendants” or “Mitsuba”), Mitsubishi Electric Corporation, Mitsubishi Electric US Holdings, Inc., and Mitsubishi Electric Automotive America, Inc. (collectively, “Mitsubishi Defendants” or “Mitsubishi”), Robert Bosch GmbH and Robert Bosch LLC (together, “Bosch Defendants” or “Bosch”), (all as defined below, and collectively “Defendants”), and unnamed co-conspirators, manufacturers and/or suppliers of Fuel Injection Systems (defined below) globally and in the United States, for engaging in a long-running conspiracy to unlawfully fix, artificially raise, maintain and/or stabilize prices, rig bids for, and allocate the market and customers in the United States for Fuel Injection Systems. According to the United States Department of Justice (“DOJ”), Defendants’ conspiracy successfully targeted the long-struggling United States automotive industry, raising prices for car manufacturers and consumers alike.

2. “Fuel Injection Systems” admit fuel or a fuel/air mixture into engine cylinders and may include injectors, high pressure pumps, rail assemblies, feed lines, electronic throttle bodies, airflow meters, engine electronic control units, fuel pumps, fuel pump modules, manifold absolute pressure sensors (“MAP Sensors”), pressure regulators, pulsation dampers, purge control valves and other components sold as a unitary system. In some instances, the component

---

<sup>1</sup> For the purposes of this Complaint, the terms “Hitachi Defendants” or “Defendants” also includes the former Hitachi Automotive Systems Group of Hitachi, Ltd., as it existed prior to July 1, 2009, the former Hitachi Unisia Automotive, Ltd. and the former Tokico, Ltd.

**REDACTED**

parts of a Fuel Injection System are sourced separately while in other instances they are sourced together. Fuel Injection Systems can also be sold as part of a broader system, such as an engine management system. Fuel Injection Systems are part of the powertrain segment of the automotive market.

3. Plaintiffs seek to represent all persons and entities who, during the period from and including January 1, 2000 through such time as the anticompetitive effects of the Defendants' conduct ceased (the "Class Period") purchased or leased a new vehicle in the United States not for resale which included one or more Fuel Injection System(s) as a component part, which were manufactured or sold by the Defendants, any current or former subsidiary of the Defendants or any co-conspirator of the Defendants.

4. Defendants manufacture, market, and/or sell Fuel Injection Systems throughout and into the United States. Defendants, and their co-conspirators (as yet unknown), agreed, combined, and conspired to fix, raise, maintain and/or stabilize prices, rig bids and allocate the market and customers in the United States for Fuel Injection Systems.

5. The DOJ's Antitrust Division is currently conducting a broad criminal investigation into illegal price-fixing and bid-rigging in the automotive parts industry. As part of its criminal investigation, the DOJ is seeking information about unlawful anticompetitive conduct in the market for a number of different but related automotive parts, and the Federal Bureau of Investigation ("FBI") has participated in raids, pursuant to search warrants, carried out in the offices of a number of major competitors in the automotive parts industry. The automotive parts investigation is the largest criminal investigation the Antitrust Division has ever pursued, both in terms of its scope and its impact on American consumers and businesses. The ongoing

**REDACTED**

cartel investigation of price-fixing and bid-rigging in the automotive parts industry has yielded more than \$2.4 billion in criminal fines.

6. Defendant Aisan Industry Co., Ltd. agreed to plead guilty to a one count criminal Information and to pay a \$6.86 million fine for its unlawful participation in a combination and conspiracy to suppress and eliminate competition in the automotive parts industry by agreeing to rig bids for, and to fix, stabilize, and maintain the prices of, electronic throttle bodies sold to Nissan Motor Co., Ltd. and certain of its subsidiaries in the United States and elsewhere, from at least as early as October 2003 until at least February 2010. The combination and conspiracy engaged in by Defendant Aisan Industry Co., Ltd. and its co-conspirators was an unreasonable restraint of interstate and foreign trade and commerce in violation of the Sherman Antitrust Act, 15 U.S.C. § 1.

7. Defendant DENSO Corporation agreed to plead guilty to a two-count criminal Information and to pay a \$78 million fine for participating in a combination and conspiracy to suppress and eliminate competition in the automotive parts industry by agreeing to rig bids for, and to fix, stabilize, and maintain the prices of, certain electronic control units (“ECUs”) and heater control panels (“HCPs”) sold to an automobile manufacturer in the United States and elsewhere from at least as early as January 2000 until at least February 2010. The combination and conspiracy engaged in by Defendant DENSO Corporation and its co-conspirators was an unreasonable restraint of interstate and foreign trade and commerce in violation of the Sherman Antitrust Act, 15 U.S.C. § 1.

8. In addition to the fact that Defendant DENSO Corporation pleaded guilty and agreed on its own behalf and on behalf of its subsidiaries to cooperating in the government’s

**REDACTED**

investigation, several of its high-ranking executives have pleaded guilty to criminal price-fixing in the automotive parts industry.

9. On March 26, 2012, the DOJ announced that Norihiro Imai, an executive of Defendant DENSO Corporation, agreed to serve one year and one day in a U.S. prison, pay a \$20,000 criminal fine, and plead guilty to a one-count criminal Information charging him with engaging in a conspiracy to rig bids for, and to fix, stabilize and maintain the prices of HCPs sold to customers in the United States and elsewhere.

10. On April 26, 2012, the DOJ announced that Makoto Hattori, an executive of Defendant DENSO Corporation, agreed to serve fourteen months in a U.S. prison, pay a \$20,000 criminal fine, and plead guilty to a one-count criminal Information charging him with engaging in a conspiracy to rig bids for, and to fix, stabilize, and maintain the prices of HCPs sold to a customer in the United States and elsewhere.

11. On May 21, 2013, the DOJ announced that Yuji Suzuki, an executive of Defendant DENSO Corporation, agreed to serve sixteen months in a U.S. prison, pay a \$20,000 criminal fine, and plead guilty to a two-count criminal Information for his role in a conspiracy to rig bids for, and to fix, stabilize, and maintain the prices of ECUs and HCPs sold in the United States and elsewhere. Also on May 21, 2013, the DOJ announced that Hiroshi Watanabe an executive of Defendant DENSO Corporation, agreed to serve fifteen months in a U.S. prison, pay a \$20,000 criminal fine, and plead guilty to a one-count criminal Information for his role in a conspiracy to rig bids for, and to fix, stabilize, and maintain the prices of HCPs sold in the United States and elsewhere.

12. On February 20, 2014, the DOJ announced that Kazuaki Fujitani, a former executive of Defendant DENSO Corporation, agreed to serve one year and one day in a U.S.

**REDACTED**

prison and plead guilty to a one-count criminal Information charging him with obstruction of justice for deleting numerous e-mails and electronic documents upon learning the FBI was executing a search warrant on Defendant DENSO International America, Inc. in connection with the DOJ's investigation into a conspiracy to fix the prices of HCPs installed in automobiles sold in the United States and elsewhere.

13. On June 30, 2014, the DOJ announced that Satoru Horisaki, a former executive of Defendant DENSO Corporation, agreed to serve one year and one day in a U.S. prison, pay a \$20,000 criminal fine, and plead guilty to a one-count criminal Information charging him with participating in a conspiracy to agree upon bids and prices for, and allocate the supply of, automotive instrument panel clusters sold to Honda of America Manufacturing Co. Inc., in the United States and elsewhere.

14. Defendant Hitachi Automotive Systems, Ltd. agreed to plead guilty and to pay a \$195 million fine for its unlawful conduct in participating in a combination and conspiracy to suppress and eliminate competition in the automotive parts industry by agreeing to allocate the supply of, rig bids for, and fix, stabilize, and maintain the prices of, certain automotive products sold to automobile manufacturers, including, Nissan Motor Company, Ltd., Honda Motor Company, Ltd., General Motors Company, Ford Motor Company, Toyota Motor Corporation, Chrysler Group LLC, and Fuji Heavy Industries Ltd., and certain of their subsidiaries, affiliates and suppliers, in the United States and elsewhere, from at least as early as January 2000 until at least February 2010. For purposes of the plea agreement between Defendant Hitachi Automotive Systems, Ltd. and the United States, "automotive parts" were defined to include, among other products, air flow meters, fuel injection systems, and electronic throttle bodies. The combination and conspiracy engaged in by Defendant Hitachi Automotive Systems, Ltd. and its co-

**REDACTED**

conspirators was an unreasonable restraint of interstate and foreign trade and commerce in violation of the Sherman Antitrust Act, 15 U.S.C. § 1.

15. On June 30, 2014, the DOJ announced that a federal grand jury returned a one-count Indictment against Takashi Toyokuni, Ken Funasaki, Kazunobu Tsunekawa and Tomiya Itakura of Hitachi Automotive Systems Ltd. for agreeing to allocate the supply of, rig bids for, and fix, stabilize and maintain the prices of, certain automotive parts sold to various automobile manufacturers such as Ford Motor Company, General Motors LLC, Nissan Motor Co. Ltd., Toyota Motor Corporation, and Honda Motor Company, Ltd., and others, and certain of their subsidiaries, in the United States and elsewhere. For purposes of the Indictment, “automotive parts” includes starter motors, alternators, air flow meters, valve timing control devices, fuel injection systems, electronic throttle bodies, ignition coils, inverters and motor generators.

16. Defendant Mitsuba Corporation agreed to plead guilty and to pay a criminal fine of \$135 million for participating in a combination and conspiracy to suppress and eliminate competition in the automotive parts industry by agreeing to rig bids for, and to fix, stabilize, and maintain the prices of, certain automotive parts sold to automobile manufacturers, including Honda Motor Company, Ltd., Fuji Heavy Industries Ltd., Nissan Motor Company, Ltd., Toyota Motor Corporation, Chrysler Group LLC, and certain of their subsidiaries, affiliates and suppliers in the United States and elsewhere, from at least as early as January 2000 through at least February 2010. “Automotive parts,” for purposes of the plea agreement, includes, among other parts, electric throttle motors and fuel pumps. The combination and conspiracy engaged in by Defendant Mitsuba Corporation and its co-conspirators was an unreasonable restraint of interstate and foreign trade and commerce in violation of the Sherman Antitrust Act, 15 U.S.C. § 1.



**REDACTED**

17. On December 1, 2014, the DOJ announced that a former executive of Defendant Mitsuba, Kazumi Umahashi, agreed to serve thirteen months in a U.S. prison, pay a \$20,000 criminal fine, and plead guilty to a one-count criminal Information charging him with conspiring to fix the prices of products installed in cars sold in the United States and elsewhere. According to the Information, Kazumi Umahashi participated in a combination and conspiracy to suppress and eliminate competition in the automotive parts industry by agreeing to rig bids for, and to fix, stabilize, and maintain the prices of, certain automotive parts, including windshield wiper systems and starter motors, sold to Honda Motor Company Ltd. and certain of its subsidiaries, affiliates, suppliers, and others in the United States and elsewhere.

18. Defendant Mitsubishi Electric Corporation agreed to plead guilty and to pay a criminal fine of \$190 million for participating in a combination and conspiracy to suppress and eliminate competition in the automotive parts industry by agreeing to rig bids for, and to fix, stabilize, and maintain the price of, certain automotive parts sold to automobile manufacturers, including Ford Motor Company, General Motors LLC, Chrysler Group LLC, Fuji Heavy Industries Ltd., Nissan Motor Company, Ltd., Honda Motor Company, Ltd., Toyota Motor Corporation, and certain of their subsidiaries, in the United States and elsewhere, from at least as early as January 2000 until at least February 2010. “Automotive parts,” for purposes of the plea agreement, includes, among other parts, fuel injections, fuel pumps, MAP sensors, purge control valves, and throttle bodies. The combination and conspiracy engaged in by Defendant Mitsubishi Electric Corporation and its co-conspirators was an unreasonable restraint of interstate and foreign trade and commerce in violation of the Sherman Antitrust Act, 15 U.S.C. § 1.

**REDACTED**

19. On June 30, 2014, the DOJ announced that a federal grand jury returned a three-count Indictment against Atsushi Ueda, Minoru Kurisaki, and Hideyuki Saito, current and former executives of Mitsubishi Electric Corporation, for their participation in a conspiracy to fix the prices of certain automotive parts, including starter motors, alternators, and ignition coils. Count One charged Atsushi Ueda, Minoru Kurisaki, and Hideyuki Saito with participating in a conspiracy to suppress and eliminate competition in the automotive parts industry by agreeing to allocate the supply of, rig bids for, and fix, stabilize, and maintain the prices of, various automotive parts sold to Ford Motor Company., General Motors LLC, Chrysler Group LLC, Fuji Heavy Industries Ltd., Nissan Motor Company Ltd., Honda Motor Company Ltd., and certain of their subsidiaries, in the United States and elsewhere. Count Two charged Minoru Kurisaki and Hideyuki Saito with knowingly conspiring to obstruct justice by destroying documents and corruptly persuading, and attempting to persuade others, to destroy documents related to an official proceeding, grand jury investigation, and U.S. agency investigation. Count Three charged Hideyuki Saito with knowingly and corruptly persuading, or attempting to persuade, other employees of Mitsubishi Electric Corporation to destroy or conceal paper documents and delete electronic data that may contain evidence of antitrust crimes in the United States and elsewhere with the intent to impair the objects' availability and integrity for use in an official proceeding.

20. The Defendants and their co-conspirators participated in a combination and conspiracy to suppress and eliminate competition in the automotive parts industry by agreeing to allocate the supply of, rig bids for, and fix, stabilize, and maintain the prices of, Fuel Injection Systems sold to vehicle manufacturers and others in the United States. The combination and conspiracy engaged in by the Defendants and their co-conspirators was an unreasonable restraint

**REDACTED**

of interstate and foreign trade and commerce in violation of the Sherman Antitrust Act, 15 U.S.C. § 1, and state antitrust, unfair competition, consumer protection and unjust enrichment laws.

21. As a direct result of the anticompetitive and unlawful conduct alleged herein, Plaintiffs and the Classes (as defined below) paid artificially inflated prices for Fuel Injection Systems during the Class Period and have thereby suffered antitrust injury to their business or property.

**JURISDICTION AND VENUE**

22. Plaintiffs bring this action under Section 16 of the Clayton Act (15 U.S.C. § 26) to secure equitable and injunctive relief against Defendants for violating Section 1 of the Sherman Act (15 U.S.C. § 1). Plaintiffs also assert claims for actual and exemplary damages pursuant to state antitrust, unfair competition, consumer protection and unjust enrichment laws, and seek to obtain restitution, recover damages and secure other relief against the Defendants for violations of those state laws. Plaintiffs and the Classes also seek attorneys' fees, costs, and other expenses under federal and state law.

23. This Court has jurisdiction over the subject matter of this action pursuant to Section 16 of the Clayton Act (15 U.S.C. § 26), Section 1 of the Sherman Act (15 U.S.C. § 1), and Title 28, United States Code, Sections 1331 and 1337. This Court has subject matter jurisdiction of the state law claims pursuant to 28 U.S.C. §§ 1332(d) and 1367, in that this is a class action in which the matter or controversy exceeds the sum of \$5,000,000, exclusive of interest and costs, and in which some members of the proposed Classes are citizens of a state different from the Defendants.

24. Venue is proper in this District pursuant to Section 12 of the Clayton Act (15 U.S.C. § 22), and 28 U.S.C. §§ 1391 (b), (c), and (d), because a substantial part of the events

**REDACTED**

giving rise to Plaintiffs' claims occurred in this District, a substantial portion of the affected interstate trade and commerce discussed below has been carried out in this District, and one or more of the Defendants reside, are licensed to do business in, are doing business in, had agents in, or are found or transact business in this District.

25. This Court has in personam jurisdiction over the Defendants because each, either directly or through the ownership and/or control of their subsidiaries, inter alia: (a) transacted business in the United States, including in this District; (b) directly or indirectly sold or marketed substantial quantities of Fuel Injection Systems throughout the United States, including in this District; (c) had substantial aggregate contacts with the United States, including in this District; or (d) were engaged in an illegal price-fixing conspiracy that was directed at, and had a direct, substantial, reasonably foreseeable and intended effect of causing injury to, the business or property of persons and entities residing in, located in, or doing business throughout the United States, including in this District. The Defendants also conduct business throughout the United States, including in this District, and have purposefully availed themselves of the laws of the United States.

26. The Defendants engaged in conduct both inside and outside of the United States that caused direct, substantial and reasonably foreseeable and intended anticompetitive effects upon interstate commerce within the United States.

27. The activities of the Defendants and their co-conspirators were within the flow of, were intended to, and did have, a substantial effect on interstate commerce of the United States. The Defendants' products are sold in the flow of interstate commerce.

28. Fuel Injection Systems manufactured abroad by the Defendants and sold for use in vehicles in the United States are goods brought into the United States for sale, and therefore

**REDACTED**

constitute import commerce. To the extent any Fuel Injection Systems are purchased in the United States, and such Fuel Injection Systems do not constitute import commerce, the Defendants' activities with respect thereto, as more fully alleged herein during the Class Period, had, and continue to have, a direct, substantial and reasonably foreseeable effect on United States commerce. The anticompetitive conduct, and its effect on United States commerce described herein, proximately caused antitrust injury in the United States.

29. By reason of the unlawful activities hereinafter alleged, the Defendants' unlawful activities substantially affected commerce throughout the United States, causing injury to Plaintiffs and members of the Classes. The Defendants, directly and through their agents, engaged in activities affecting all states, to fix, raise, maintain and/or stabilize prices, rig bids and allocate the market and customers in the United States for Fuel Injection Systems, which conspiracy unreasonably restrained trade and adversely affected the market for Fuel Injection Systems.

30. The Defendants' conspiracy and wrongdoing described herein adversely affected persons in the United States who purchased or leased a new vehicle in the United States not for resale which included one or more Fuel Injection Systems.

**PARTIES**

**Plaintiffs**

31. Plaintiff Ifeoma Adams is a California resident who purchased at least one Fuel Injection System indirectly from at least one Defendant.

32. Plaintiff Halley Ascher is a District of Columbia resident who purchased at least one Fuel Injection System indirectly from at least one Defendant.

33. Plaintiff Gregory Asken is a Nevada resident who purchased at least one Fuel Injection System indirectly from at least one Defendant.

**REDACTED**

34. Plaintiff Melissa Barron is a California resident who purchased at least one Fuel Injection System indirectly from at least one Defendant.

35. Plaintiff Kimberly Bennett is an Arkansas resident who purchased at least one Fuel Injection System indirectly from at least one Defendant.

36. Plaintiff David Bernstein is a Minnesota resident who purchased at least one Fuel Injection System indirectly from at least one Defendant.

37. Plaintiff Ron Blau is a Massachusetts resident who purchased at least one Fuel Injection System indirectly from at least one Defendant.

38. Plaintiff Tenisha Burgos is a New York resident who purchased at least one Fuel Injection System indirectly from at least one Defendant.

39. Plaintiff Kent Busek is a North Dakota resident who purchased at least one Fuel Injection System indirectly from at least one Defendant.

40. Plaintiff Jennifer Chase is an Iowa resident who purchased at least one Fuel Injection System indirectly from at least one Defendant.

41. Plaintiff Rita Cornish is a Utah resident who purchased at least one Fuel Injection System indirectly from at least one Defendant.

42. Plaintiff Nathan Croom is a Nebraska resident who purchased at least one Fuel Injection System indirectly from at least one Defendant.

43. Plaintiff Lori Curtis is a Missouri resident who purchased at least one Fuel Injection System indirectly from at least one Defendant.

44. Plaintiff Jessica DeCastro is a Missouri resident who purchased at least one Fuel Injection System indirectly from at least one Defendant.

**REDACTED**

45. Plaintiff Alena Farrell is a Vermont resident who purchased at least one Fuel Injection System indirectly from at least one Defendant.

46. Plaintiff Jane Fitzgerald is a Vermont resident who purchased at least one Fuel Injection System indirectly from at least one Defendant.

47. Plaintiff Carroll Gibbs is a District of Columbia resident who purchased at least one Fuel Injection System indirectly from at least one Defendant.

48. Plaintiff Dori Gilels is a Montana resident who purchased at least one Fuel Injection System indirectly from at least one Defendant.

49. Plaintiff Jason Grala is a New York resident who purchased at least one Fuel Injection System indirectly from at least one Defendant.

50. Plaintiff Ian Groves is a New Mexico resident who purchased at least one Fuel Injection System indirectly from at least one Defendant.

51. Plaintiff Curtis Gunnerson is a Minnesota resident who purchased at least one Fuel Injection System indirectly from at least one Defendant.

52. Plaintiff Paul Gustafson is an Oregon resident who purchased at least one Fuel Injection System indirectly from at least one Defendant.

53. Plaintiff Tom Halverson is an Arizona resident who purchased at least one Fuel Injection System indirectly from at least one Defendant.

54. Plaintiff Curtis Harr is a North Dakota resident who purchased at least one Fuel Injection System indirectly from at least one Defendant.

55. Plaintiff Andrew Hedlund is a South Carolina resident who purchased at least one Fuel Injection System indirectly from at least one Defendant.

**REDACTED**

56. Plaintiff Gary Arthur Herr is a Florida resident who purchased at least one Fuel Injection System indirectly from at least one Defendant.

57. Plaintiff John Hollingsworth is a California resident who purchased at least one Fuel Injection System indirectly from at least one Defendant.

58. Plaintiff Leonard Julian is a Nevada resident who purchased at least one Fuel Injection System indirectly from at least one Defendant.

59. Plaintiff Carol Ann Kashishian is a Wisconsin resident who purchased at least one Fuel Injection System indirectly from at least one Defendant.

60. Plaintiff Elizabeth Kaufman is a Florida resident who purchased at least one Fuel Injection System indirectly from at least one Defendant.

61. Plaintiff Robert Klingler is a Missouri resident who purchased at least one Fuel Injection System indirectly from at least one Defendant.

62. Plaintiff Kelly Klosterman is a North Dakota resident who purchased at least one Fuel Injection System indirectly from at least one Defendant.

63. Plaintiff James Marean is a Maine resident who purchased at least one Fuel Injection System indirectly from at least one Defendant.

64. Plaintiff Michelle McGinn is a Nevada resident who purchased at least one Fuel Injection System indirectly from at least one Defendant.

65. Plaintiff Nilsa Mercado is a Michigan resident who purchased at least one Fuel Injection System indirectly from at least one Defendant.

66. Plaintiff Rebecca Lynn Morrow is an Arizona resident who purchased at least one Fuel Injection System indirectly from at least one Defendant.



**REDACTED**

67. Plaintiff Edward Muscara is a New Hampshire resident who purchased at least one Fuel Injection System indirectly from at least one Defendant.

68. Plaintiff Stacey Nickell is a West Virginia resident who purchased at least one Fuel Injection System indirectly from at least one Defendant.

69. Plaintiff Sophie O'Keefe-Zelman is an Arizona resident who purchased at least one Fuel Injection System indirectly from at least one Defendant.

70. Plaintiff Roger Olson is a Michigan resident who purchased at least one Fuel Injection System indirectly from at least one Defendant.

71. Plaintiff Susan Olson is a Michigan resident who purchased at least one Fuel Injection System indirectly from at least one Defendant.

72. Plaintiff William Picotte is a Washington resident who purchased at least one Fuel Injection System indirectly from at least one Defendant while a resident of South Dakota.

73. Plaintiff Whitney Porter is a District of Columbia resident who purchased at least one Fuel Injection System indirectly from at least one Defendant.

74. Plaintiff Cindy Prince is a Hawaii resident who purchased at least one Fuel Injection System indirectly from at least one Defendant while a resident of Oregon.

75. Plaintiff Janne Rice is a West Virginia resident who purchased at least one Fuel Injection System indirectly from at least one Defendant.

76. Plaintiff Robert Rice, Jr. is a West Virginia resident who purchased at least one Fuel Injection System indirectly from at least one Defendant.

77. Plaintiff Frances Gammell-Roach is a Rhode Island resident who purchased at least one Fuel Injection System indirectly from at least one Defendant.

**REDACTED**

78. Plaintiff Darrel Senior is a Kansas resident who purchased at least one Fuel Injection System indirectly from at least one Defendant.

79. Plaintiff Meetesh Shah is a California resident who purchased at least one Fuel Injection System indirectly from at least one Defendant.

80. Plaintiff Darcy Sherman is a Minnesota resident who purchased at least one Fuel Injection System indirectly from at least one Defendant.

81. Plaintiff Erica Shoaf is an Arizona resident who purchased at least one Fuel Injection System indirectly from at least one Defendant.

82. Plaintiff Arthur Stukey is a Vermont resident who purchased at least one Fuel Injection System indirectly from at least one Defendant.

83. Plaintiff Kathleen Tawney is a North Carolina resident who purchased at least one Fuel Injection System indirectly from at least one Defendant.

84. Plaintiff Jane Taylor is a Hawaii resident who purchased at least one Fuel Injection System indirectly from at least one Defendant.

85. Plaintiff Keith Uehara is a Hawaii resident who purchased at least one Fuel Injection System indirectly from at least one Defendant.

86. Plaintiff Michael Wick is a New Mexico resident who purchased at least one Fuel Injection System indirectly from at least one Defendant.

87. Plaintiff Thomas Wilson is a Mississippi resident who purchased at least one Fuel Injection System indirectly from at least one Defendant.

88. Plaintiff Phillip Young is a Tennessee resident who purchased at least one Fuel Injection System indirectly from at least one Defendant.

**Defendants**

**REDACTED**

**Aisan Defendants**

89. Defendant Aisan Industry Co., Ltd. is a Japanese corporation with its principal place of business in Obu, Japan. Aisan Industry Co., Ltd. – directly and/or through its subsidiaries, which it wholly owned and/or controlled – manufactured, marketed and/or sold Fuel Injection Systems that were purchased throughout the United States, including in this District, during the Class Period.

90. Defendant Franklin Precision Industry, Inc. is a Kentucky corporation with its principal place of business in Franklin, Kentucky. Franklin Precision Industry, Inc. is a subsidiary of and wholly owned and/or controlled by its parent, Aisan Industry Co., Ltd. Franklin Precision Industry, Inc. manufactured, marketed and/or sold Fuel Injection Systems that were purchased throughout the United States, including in this District, during the Class Period. At all times during the Class Period, its activities in the United States were under the control and direction of its Japanese parent.

91. Defendant Aisan Corporation of America is an Illinois corporation with its principal place of business in Franklin, Tennessee. Aisan Corporation of America is a subsidiary of and wholly owned and/or controlled by its parent, Aisan Industry Co., Ltd. Aisan Corporation of America manufactured, marketed and/or sold Fuel Injection Systems that were purchased throughout the United States, including in this District, during the Class Period. At all times during the Class Period, its activities in the United States were under the control and direction of its Japanese parent.

92. Defendant Hyundam Industrial Co., Ltd. is a Korean corporation with its principal place of business in Asan-si, South Korea. It is a subsidiary of and wholly owned and/or controlled by its parent, Aisan Industry Co., Ltd. Defendant Hyundam Industrial Co., Ltd.

**REDACTED**

manufactured, marketed and/or sold Fuel Injection Systems that were purchased throughout the United States, including in this District, during the Class Period. At all times during the Class Period, its activities in the United States were under the control and direction of its Japanese parent.

**DENSO Defendants**

93. Defendant DENSO Corporation is a Japanese corporation with its principal place of business in Kariya, Japan. Defendant DENSO Corporation – directly and/or through its subsidiaries, which it wholly owned and/or controlled – manufactured, marketed and/or sold Fuel Injection Systems that were purchased throughout the United States, including in this district, during the Class Period.

94. Defendant DENSO International America, Inc. is a Delaware corporation with its principal place of business in Southfield, Michigan. It is a subsidiary of and wholly owned and/or controlled by its parent, DENSO Corporation. Defendant DENSO International America, Inc. manufactured, marketed and/or sold Fuel Injection Systems that were purchased throughout the United States, including in this District, during the Class Period. At all times during the Class Period, its activities in the United States were under the control and direction of its Japanese parent.

95. Defendant DENSO International Korea Corporation is a Korean corporation with its principal place of business in Uiwang-si, South Korea. It is a subsidiary of and wholly owned and/or controlled by its parent, DENSO Corporation. Defendant DENSO International Korea Corporation manufactured, marketed and/or sold Fuel Injection Systems that were purchased throughout the United States, including in this District, during the Class Period. At all times

**REDACTED**

during the Class Period, its activities in the United States were under the control and direction of its Japanese parent.

**Hitachi Defendants**

96. Defendant Hitachi Automotive Systems, Ltd. is a Japanese corporation with its principal place of business in Tokyo, Japan. Hitachi Automotive Systems, Ltd. – directly and/or through its subsidiaries, which it wholly owned and/or controlled – manufactured, marketed and/or sold Fuel Injection Systems that were purchased throughout the United States, including in this District, during the Class Period.

97. Defendant Hitachi Automotive Systems Americas, Inc. is a Delaware corporation with its principal place of business in Harrodsburg, Kentucky. It is a subsidiary of and wholly owned and/or controlled by its parent, Hitachi Automotive Systems, Ltd. Hitachi Automotive Systems Americas, Inc. manufactured, marketed and/or sold Fuel Injection Systems that were purchased throughout the United States, including in this District, during the Class Period. At all times during the Class Period, its activities in the United States were under the control and direction of its Japanese parent.

**Keihin Defendants**

98. Defendant Keihin Corporation is a Japanese corporation with its principal place of business in Tokyo, Japan. Keihin Corporation – directly and/or through its subsidiaries, which it wholly owned and/or controlled – manufactured, marketed and/or sold Fuel Injection Systems that were purchased throughout the United States, including in this District, during the Class Period.

99. Defendant Keihin North America, Inc. is an Indiana corporation with its principal place of business in Anderson, Indiana. Keihin North America, Inc. – directly and/or through its

**REDACTED**

subsidiaries, which it wholly owned and/or controlled – manufactured, marketed and/or sold Fuel Injection Systems that were purchased throughout the United States, including in this District, during the Class Period. At all times during the Class Period, its activities in the United States were under the control and direction of its Japanese parent.

**Maruyasu**

100. Maruyasu Industries Co., Ltd. is a Japanese corporation with its principal place of business in Nagoya-shi, Japan. Maruyasu Industries Co., Ltd. – directly and/or through its subsidiaries, which it wholly owned and/or controlled – manufactured, marketed and/or sold Fuel Injection Systems that were purchased throughout the United States, including in this District, during the Class Period.

**Mikuni Defendants**

101. Defendant Mikuni Corporation is a Japanese corporation with its principal place of business in Tokyo, Japan. Defendant Mikuni Corporation – directly and/or through its subsidiaries, which it wholly owned and/or controlled – manufactured, marketed and/or sold Fuel Injection Systems that were purchased throughout the United States, including in this District, during the Class Period.

102. Defendant Mikuni American Corporation is a California corporation with its principal place of business in Northridge, California. It is a subsidiary of and wholly owned and/or controlled by its parent, Mikuni Corporation. Defendant Mikuni American Corporation – directly and/or through its subsidiaries, which it wholly owned and/or controlled – manufactured, marketed and/or sold Fuel Injection Systems that were purchased throughout the United States, including in this District, during the Class Period. At all times during the Class Period, its activities in the United States were under the control and direction of its Japanese parent.

**REDACTED**

**Mitsubishi Defendants**

103. Defendant Mitsubishi Electric Corporation is a Japanese corporation with its principal place of business in Tokyo, Japan. Defendant Mitsubishi Electric Corporation – directly and/or through its subsidiaries, which it wholly owned and/or controlled – manufactured, marketed and/or sold Fuel Injection Systems that were purchased throughout the United States, including in this District, during the Class Period.

104. Defendant Mitsubishi Electric US Holdings, Inc. is a Delaware corporation with its principal place of business in Cypress, California. It is a subsidiary of and wholly owned and/or controlled by its parent, Mitsubishi Electric Corporation. Defendant Mitsubishi Electric US Holdings, Inc. – directly and/or through its subsidiaries, which it wholly owned and/or controlled – manufactured, marketed and/or sold Fuel Injection Systems that were purchased throughout the United States, including in this District, during the Class Period. At all times during the Class Period, its activities in the United States were under the control and direction of its Japanese parent.

105. Defendant Mitsubishi Electric Automotive America, Inc. is a Delaware corporation with its principal place of business in Mason, Ohio. It is a subsidiary of and wholly owned and/or controlled by its parent, Mitsubishi Electric US Holdings. Defendant Mitsubishi Electric Automotive America, Inc. manufactured, marketed and/or sold Fuel Injection Systems that were purchased throughout the United States, including in this District, during the Class Period. At all times during the Class Period, its activities in the United States were under the control and direction of its United States or Japanese parents.

**Mitsuba Defendants**

**REDACTED**

106. Defendant Mitsuba Corporation is a Japanese corporation with its principal place of business in Gunma, Japan. Mitsuba Corporation – directly and/or through its subsidiaries, which it wholly owned and/or controlled – manufactured, marketed and/or sold Fuel Injector Systems that were purchased throughout the United States, including in this District, during the Class Period.

107. Defendant American Mitsuba Corporation is an Illinois corporation with its principal place of business in Novi, Michigan. It is a subsidiary of and wholly owned and/or controlled by its parent, Mitsuba Corporation. American Mitsuba Corporation manufactured, marketed and/or sold Fuel Injection Systems that were purchased throughout the United States, including in this District, during the Class Period. At all times during the Class Period, its activities in the United States were under the control and direction of its Japanese parent.

**Bosch Defendants**

108. Defendant Robert Bosch GmbH is a German company with its headquarters in Stuttgart, Germany. Robert Bosch GmbH – directly and/or through its subsidiaries, which it wholly owned and/or controlled – manufactured, marketed and/or sold Fuel Injection Systems that were purchased throughout the United States, including in this District, during the Class Period.

109. Defendant Robert Bosch LLC is a Delaware company with its principal place of business in Farmington Hills, Michigan. It is an affiliate of and wholly controlled by Robert Bosch GmbH. Robert Bosch LLC – directly and/or through its subsidiaries, which it wholly owned and/or controlled – manufactured, marketed and/or sold Fuel Injection Systems that were purchased throughout the United States, including in this District, during the Class Period. At all



**REDACTED**

times during the Class Period, its activities in the United States were under the control and direction of its Korean parent.

### **AGENTS AND CO-CONSPIRATORS**

110. Each Defendant acted as the principal of or agent for the other Defendant with respect to the acts, violations, and common course of conduct alleged herein.

111. Various persons, partnerships, sole proprietors, firms, corporations and individuals not named as defendants in this lawsuit, and individuals, the identities of which are presently unknown, have participated as co-conspirators with the Defendants in the offenses alleged in this Complaint, and have performed acts and made statements in furtherance of the conspiracy or in furtherance of the anticompetitive conduct.

112. Whenever in this Complaint reference is made to any act, deed or transaction of any corporation or limited liability entity, the allegation means that the corporation or limited liability entity engaged in the act, deed or transaction by or through its officers, directors, agents, employees or representatives while they were actively engaged in the management, direction, control or transaction of the corporation's or limited liability entity's business or affairs.

### **FACTUAL ALLEGATIONS**

#### **A. The Fuel Injection Systems Industry**

113. "Fuel Injection Systems" admit fuel or a fuel/air mixture into engine cylinders and may include injectors, high pressure pumps, rail assemblies, feed lines, electronic throttle bodies, airflow meters, engine electronic control units, fuel pumps, MAP sensors, pressure regulators, pulsation dampers, purge control valves and other components sold as a unitary system. Fuel Injection Systems can also be sold as part of a broader system, such as an engine management system. Fuel Injection Systems are part of the powertrain segment of the automotive market.

**REDACTED**

114. The Fuel Injection System is responsible for injection timing, atomization, and injection quality of the fuel supplied to the engine.

115. In 2012, the Fuel Injection Systems market was estimated as a \$47 billion dollar global market. According to a May 2013 report by Industry Analysts, Inc., “Global Automotive Electric Fuel Pumps Industry,” Defendant DENSO Corporation is one of four dominant players in the industry. Defendant DENSO Corporation, self-labeled as a “worldwide market leader” in fuel injection products, declared that its “compact, high-durability, high-pressure fuel pump has become a de facto standard in the industry.”

116. In 2010, Toyota named Defendant DENSO Corporation as its top North American supplier of fuel injectors and fuel pump assemblies.

117. Several illustrations of Fuel Injectors and other Fuel Injection Systems component parts are set forth below.

**ELECTRONIC FUEL INJECTION SYSTEM COMPONENTS**



REDACTED

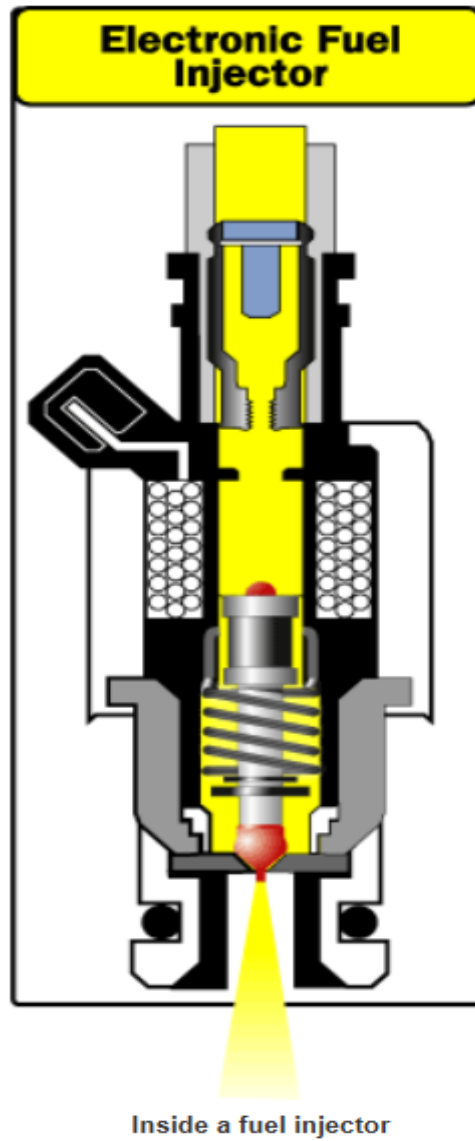

Figure 3.

REDACTED

**HITACHI MANUFACTURED AIR FLOW METER**

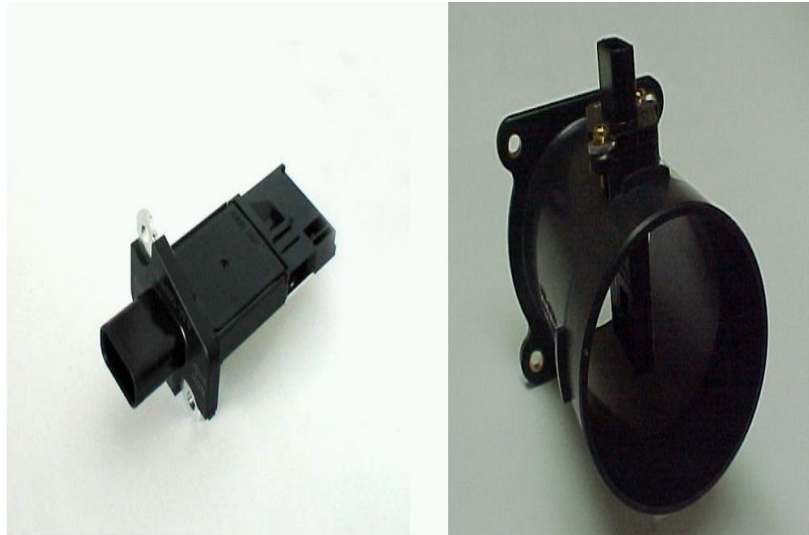

Figure 4.

**AIR FLOW METER DIAGRAM**

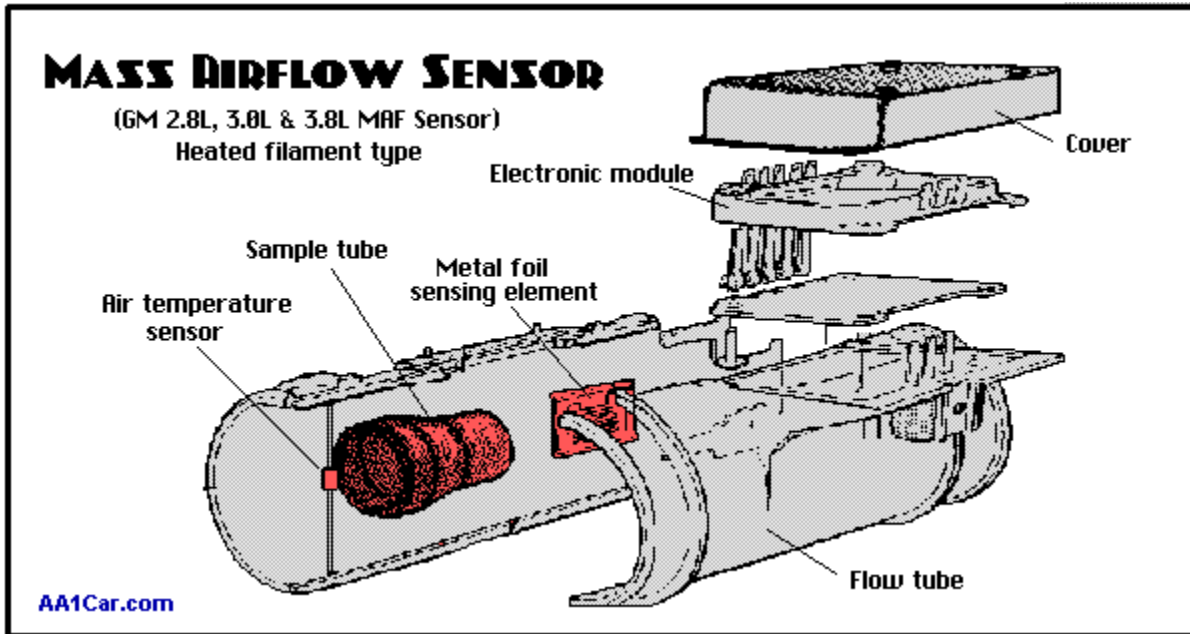

Figure 5.

REDACTED

**HITACHI MANUFACTURED ELECTRONIC THROTTLE BODY**



Figure 6.

**HITACHI ELECTRONIC CONTROL THROTTLE DIAGRAM**

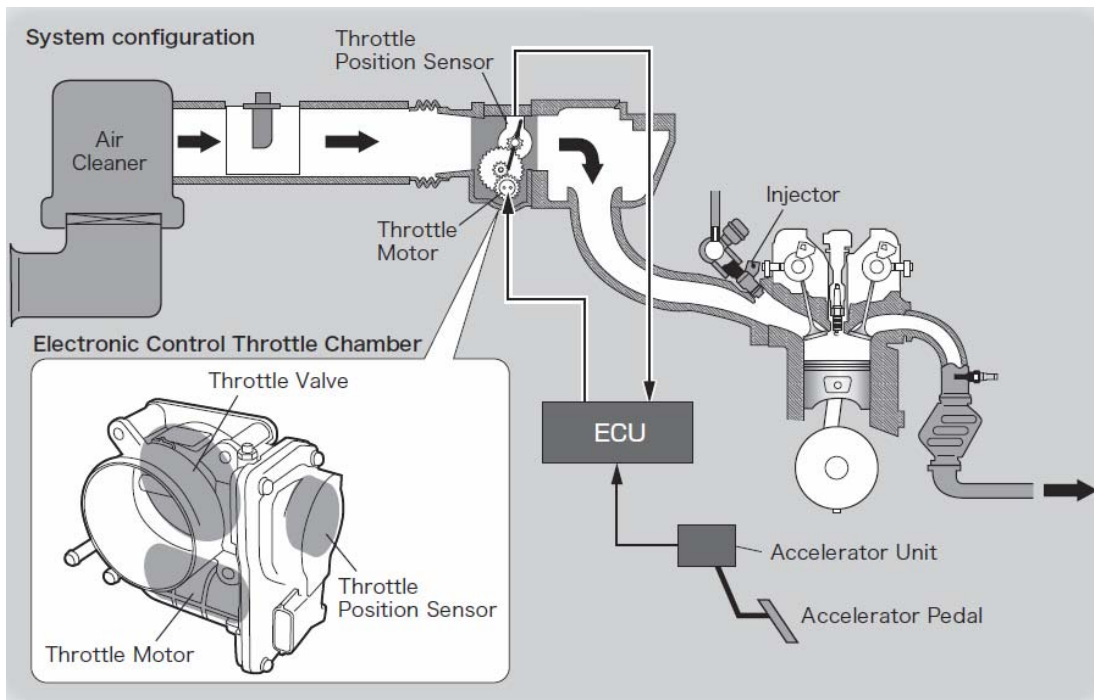

**REDACTED**

Figure 7.

118. Fuel Injection Systems are installed by original equipment manufacturers (“OEMs”) in new cars as part of the automotive manufacturing process.

119. For new cars, the OEMs – mostly large automotive manufacturers such as Ford Motor Company, Toyota Motor Corporation, General Motors, etc. – purchase Fuel Injection Systems directly from Defendants. Fuel Injection Systems may also be purchased by component manufacturers who then supply such systems to OEMs. These component manufacturers are also called “Tier 1 Manufacturers” in the industry. Tier 1 Manufacturers supply Fuel Injection Systems directly to an OEM.

120. When purchasing Fuel Injection Systems, OEMs issue Requests for Quotation (“RFQs”) to automotive parts suppliers on a model-by-model basis for model-specific parts. Automotive parts suppliers submit quotations, or bids, to OEMs in response to RFQs, and the OEMs usually award the business to the selected automotive parts supplier for the lifespan of the model, which is usually four to six years. Typically, the bidding process begins approximately three years prior to the start of production of a new model. OEMs procure Fuel Injection Systems and other parts for U.S.-manufactured vehicles in the United States and elsewhere.

121. Defendants and their co-conspirators supplied Fuel Injection Systems to OEMs for installation in vehicles manufactured and sold in the United States and elsewhere. Defendants and their co-conspirators manufactured Fuel Injection Systems (a) in the United States for installation in vehicles manufactured and sold in the United States, (b) in Japan and elsewhere for export to the United States and installation in vehicles manufactured and sold in the United States, and (c) in Japan and elsewhere for installation in vehicles manufactured in Japan and elsewhere for export to and sale in the United States.

**REDACTED**

122. Plaintiffs and members of the proposed Classes purchased Fuel Injection Systems indirectly from one or more of the Defendants. By way of example, an owner of a vehicle may indirectly purchase one or more Fuel Injection System(s) from the Defendants as part of purchasing or leasing a new vehicle.

**B. The Structure and Characteristics of the Fuel Injection Systems Market Render the Conspiracy More Plausible**

123. The structure and other characteristics of the Fuel Injection Systems market in the United States are conducive to a price-fixing agreement and have made collusion particularly attractive in this market. Specifically, the Fuel Injection Systems market: (1) has high barriers to entry; and (2) has inelasticity of demand.

**1. The Fuel Injection Systems Market Has High Barriers to Entry**

124. A collusive arrangement that raises product prices above competitive levels would, under basic economic principles, attract new entrants seeking to benefit from the supra-competitive pricing. Where, however, there are significant barriers to entry, new entrants are less likely to enter the market. Thus, barriers to entry help to facilitate the formation and maintenance of a cartel.

125. There are substantial barriers that preclude, reduce, or make more difficult entry into the Fuel Injection Systems market. A new entrant into the business would face costly and lengthy start-up costs, including multi-million dollar costs associated with manufacturing plants and equipment, energy, transportation, distribution infrastructure, skilled labor, and long-standing customer relationships.

126. The Defendants own several patents related to the manufacture of Fuel Injection Systems. For example, the Hitachi Defendants own at least two patents related to the manufacture of electronic throttle bodies, a type of throttle body. These patents place a



**REDACTED**

significant and costly burden on potential new entrants, who must avoid infringing on the patents when entering the market with a new product.

127. Within the Fuel Injection System, there is a significant amount of technology and engineering expertise required to build systems that fully comply with environmental and public health requirements and other regulatory standards, including fuel economy requirements.

128. In addition, OEMs cannot change Fuel Injection Systems suppliers randomly after they choose one because the OEMs design the features of their vehicles so that the Fuel Injection Systems it purchases for a vehicle are then integrated with the other components of the powertrain system of the particular vehicle model. Thus, Fuel Injection Systems manufacturers and OEMs must agree on a design that is unique to a particular vehicle model. It would be difficult for a new market entrant to do so.

**2. There is Inelasticity of Demand for Fuel Injection Systems**

129. “Elasticity” is a term used to describe the sensitivity of supply and demand to changes in one or the other. For example, demand is said to be “inelastic” if an increase in the price of a product results in only a small decline in the quantity sold of that product, if any. In other words, customers have nowhere to turn for alternative, cheaper products of similar quality, and so continue to purchase despite a price increase.

130. For a cartel to profit from raising prices above competitive levels, demand must be relatively inelastic at competitive prices. Otherwise, increased prices would result in declining sales, revenues and profits, as customers purchased substitute products or declined to buy altogether. Inelastic demand is a market characteristic that facilitates collusion, allowing producers to raise their prices without triggering customer substitution and lost sales revenue.

131. Demand for Fuel Injection Systems is highly inelastic. Demand for Fuel Injection Systems is inelastic because there are no close substitutes for these products. In addition,

**REDACTED**

customers must purchase Fuel Injection Systems as an essential part of a vehicle, even if the prices are kept at a supra-competitive level.

**C. Government Investigations**

132. A globally coordinated antitrust investigation is taking place in the United States, Europe, Canada and Japan, aimed at suppliers of automotive parts in general, and Fuel Injector Systems in particular. A Japan Fair Trade Commission (“JFTC”) official told a leading legal publication that the international automotive parts investigation would continue to widen because the automotive industry as a whole comprises many sub-industries. He characterized the investigation being conducted by the international antitrust authorities as “large and broad,” and he declined to deny that this “would be history’s largest case.”

133. The antitrust probe originated in Europe as the result of several European OEMs coming together to bring a complaint to the European Commission (“EC”). The EC and the FBI have executed surprise raids at the European and U.S. offices of several auto parts manufacturers, including certain Defendants, as part of an investigation into anticompetitive conduct related to the manufacturing and sale of automotive parts.

134. On February 8, 2010, the EC executed surprise raids at the European offices of certain automotive parts makers. The DOJ has confirmed that its automotive parts investigation is the largest criminal investigation that the Antitrust Division has ever pursued, both in terms of its scope and the potential volume of commerce affected by the illegal conduct. To date, the DOJ has levied more than \$3.4 billion in criminal fines against various automotive parts manufacturers.

**REDACTED**

135. In February 2010, the JFTC raided the Tokyo offices of DENSO Corporation as part of an expansive investigation into collusion in the automotive parts industry dating back to at least 2000.

136. The JFTC raided offices of Defendants as part of the spreading investigation into suspected price fixing of automotive parts. According to its 2011 Annual Report, DENSO Corporation's offices were searched on July 20, 2011 at various locations, including in Kariya, Aichi and some other sales branches in Japan. And according to its 2011 Annual Report, Mitsubishi Electric Corporation has been subject to investigations conducted by the JFTC since July 2011.

137. The DOJ has stated that it is conducting an investigation of potential antitrust activity and coordinating its investigation with antitrust regulators in Europe. "The antitrust division is investigating the possibility of anticompetitive cartel conduct of automotive electronic component suppliers," Justice Department Spokeswoman Gina Talamona said.

138. Indeed, on February 23, 2010, around the same time as the raids by the Japanese and European competition authorities, investigators from the FBI raided three Detroit-area Japanese auto parts makers as part of a federal antitrust investigation. The FBI executed warrants and searched the offices of these companies, including DENSO Corporation's subsidiary in Southfield, Michigan. Special Agent Sandra Berchtold said the affidavits supporting issuance of the warrants were sealed in federal court.

139. To obtain search warrants, the United States was legally required to have probable cause, accepted by a magistrate, to believe that it would obtain evidence of an antitrust violation as a result of executing the search warrant – that is, the United States had to have evidence sufficient to warrant a person of reasonable caution to believe that raiding the offices of a

**REDACTED**

seemingly lawful business would uncover evidence of antitrust violations and that claimed evidence must have been examined and accepted by a magistrate. That belief, which was recounted in sworn affidavits or testimony, must be grounded on reasonably trustworthy information.

**Defendant DENSO Corporation Pleads Guilty to Price-Fixing ECUs and HCPs**

140. On January 30, 2012, the DOJ announced that Defendant DENSO Corporation had agreed to pay a \$78 million fine and plead guilty to a two-count criminal Information charging it with: (1) participating in a combination and conspiracy to suppress and eliminate competition in the automotive parts industry by agreeing to rig bids for, and to fix, stabilize, and maintain the prices of, electronic control units (“ECUs”) sold to an automobile manufacturer in the United States and elsewhere from at least as early as January 2000 and until at least February 2010 in violation of the Sherman Antitrust Act, 15 U.S.C. § 1; and (2) participating in a combination and conspiracy to suppress and eliminate competition in the automotive parts industry by agreeing to rig bids for, and to fix, stabilize, and maintain the prices of, heater control panels (“HCPs”) sold to an automobile manufacturer in the United States and elsewhere from at least as early as January 2000 and continuing until at least February 2010 in violation of the Sherman Act, 15 U.S.C. § 1.

141. According to the criminal Information filed against it, Defendant DENSO Corporation and its co-conspirators carried out the ECU conspiracy by:

- (a) participating in meetings, conversations, and communications in the United States and Japan to discuss the bids and price quotations to be submitted to an automobile manufacturer in the United States and elsewhere;

**REDACTED**

- (b) agreeing, during those meetings, conversations, and communications, on bids and price quotations to be submitted to an automobile manufacturer in the United States and elsewhere;
- (c) agreeing, during those meetings, conversations, and communications, to allocate the supply of ECUs sold to an automobile manufacturer in the United States and elsewhere on a model-by-model basis;
- (d) agreeing, during those meetings, conversations, and communications, to coordinate price adjustments requested by an automobile manufacturer in the United States and elsewhere;
- (e) submitting bids, price quotations, and price adjustments to an automobile manufacturer in the United States and elsewhere in accordance with the agreements reached;
- (f) selling ECUs to an automobile manufacturer in the United States and elsewhere at collusive and noncompetitive prices;
- (g) accepting payment for ECUs sold to an automobile manufacturer in the United States and elsewhere at collusive and non-competitive prices;
- (h) engaging in meetings, conversations, and communications in the United States and elsewhere for the purpose of monitoring and enforcing adherence to the agreed-upon bid-rigging and price-fixing scheme; and
- (i) employing measures to keep their conduct secret, including but not limited to using code names and meeting at private residences or remote locations.

142. According to the criminal Information filed against it, Defendant DENSO Corporation and its co-conspirators carried out the HCP conspiracy by:

**REDACTED**

- (a) participating in meetings, conversations, and communications in the United States and Japan to discuss the bids and price quotations to be submitted to an automobile manufacturer in the United States and elsewhere;
- (b) agreeing, during those meetings, conversations, and communications, on bids and price quotations to be submitted to an automobile manufacturer in the United States and elsewhere;
- (c) agreeing, during those meetings, conversations, and communications, to allocate the supply of HCPs sold to an automobile manufacturer in the United States and elsewhere on a model-by-model basis;
- (d) agreeing, during those meetings, conversations, and communications, to coordinate price adjustments requested by an automobile manufacturer in the United States and elsewhere;
- (e) submitting bids, price quotations, and price adjustments to an automobile manufacturer in the United States and elsewhere in accordance with the agreements reached;
- (f) selling HCPs to an automobile manufacturer in the United States and elsewhere at collusive and noncompetitive prices;
- (g) accepting payment for HCPs sold to an automobile manufacturer in the United States and elsewhere at collusive and noncompetitive prices;
- (h) engaging in meetings, conversations, and communications in the United States and elsewhere for the purpose of monitoring and enforcing adherence to the agreed-upon bid-rigging and price-fixing scheme; and

**REDACTED**

- (i) employing measures to keep their conduct secret, including but not limited to using code names and meeting at private residences or remote locations.

**Defendant Hitachi Automotive Systems, Ltd. Pleads Guilty to Price-Fixing Certain Automotive Parts**

143. On September 26, 2013, the DOJ announced that Defendant Hitachi Automotive Systems, Ltd. agreed to pay a \$195 million criminal fine and to plead guilty to a one-count criminal Information charging it with participating in a conspiracy to rig bids for, and to fix, stabilize, and maintain the prices of automotive parts, including: (1) Fuel Injection Systems sold to General Motors Company, Nissan Motor Company, Ltd., and certain of their subsidiaries; (2) electronic throttle bodies sold to General Motors Company and Nissan Motor Company, Ltd., and certain of their subsidiaries; and (3) air flow meters sold to Nissan Motor Company, Ltd., and certain of its subsidiaries in the United States and elsewhere from at least as early as January 2000 and continuing until at least February 2010 in violation of the Sherman Act, 15 U.S.C. § 1.

144. According to the Information filed, Defendant Hitachi Automotive Systems, Ltd. and its co-conspirators carried out the auto parts combination and conspiracy by:

- (a) participating in meetings, conversations, and communications in the United States and elsewhere to discuss the bids and price quotations to be submitted to automobile manufacturers in the United States and elsewhere;
- (b) agreeing, during those meetings, conversations, and communications, on bids and price quotations to be submitted to automobile manufacturers in the United States and elsewhere;
- (c) agreeing, during those meetings, conversations, and communications, to allocate the supply of automotive parts sold to automobile manufacturers in the United States and elsewhere;

**REDACTED**

- (d) agreeing, during those meetings, conversations, and communications, to coordinate price adjustments requested by automobile manufacturers in the United States and elsewhere;
- (e) submitting bids, price quotations, and price adjustments to automobile manufacturers in the United States and elsewhere in accordance with the agreements reached;
- (f) selling automotive parts to automobile manufacturers in the United States and elsewhere at collusive and noncompetitive prices;
- (g) accepting payment for automotive parts sold to automobile manufacturers in the United State and elsewhere at collusive and noncompetitive prices;
- (h) engaging in meetings, conversations, and communications in the United States and elsewhere for the purpose of monitoring and enforcing adherence to the agreed-upon bid-rigging and price-fixing scheme; and
- (i) employing measures to keep their conduct secret, including, but not limited to, using code names and meeting at remote locations.

**Defendant Mitsuba Corporation Pleads Guilty to Price-Fixing Certain Automotive Parts**

145. On September 26, 2013, the DOJ announced that Defendant Mitsuba Corporation agreed to pay a \$135 million criminal fine and plead guilty to a two-count criminal Information charging it with: (i) participating in a combination and conspiracy to suppress and eliminate competition in automotive parts industry by agreeing to rig bids for, and to fix, stabilize, and maintain the prices of, certain automotive parts sold to automobile manufacturers, including Honda Motor Company Ltd., Fuji Heavy Industries Ltd., Nissan Motor Company Ltd., Toyota Motor Corporation, Chrysler Group, LLC, and certain of their subsidiaries in the United States



**REDACTED**

and elsewhere, from at least as early as January 2000 through at least February 2010, in violation of the Sherman Antitrust Act, 15 U.S.C. § 1; and (ii) altering, destroying, mutilating, concealing, covering up, falsifying and making false entries in documents and tangible objects with the intent to impede, obstruct, and influence the investigation of the conduct charged in the other count, and in relation to and contemplation of such investigation, in violation of 18 U.S.C. § 1519. For purposes of Mitsuba's plea agreement, "automotive parts" are defined to include, among other automotive products, electric throttle motors and fuel pumps.

146. According to the Information filed, Defendant Mitsuba Corporation and its co-conspirators carried out the automotive parts combination and conspiracy by, among other things, the following:

- (a) participating in meetings, conversations, and communications in the United States and elsewhere to discuss the bids and price quotations to be submitted to automobile manufacturers in the United States and elsewhere;
- (b) agreeing, during those meetings, conversations, and communications, on bids and price quotations to be submitted to automobile manufacturers in the United States and elsewhere;
- (c) agreeing, during those meetings, conversations, and communications, to allocate the supply of certain automotive parts sold to automobile manufacturers in the United States and elsewhere;
- (d) agreeing, during those meetings, conversations, and communications, to coordinate price adjustments requested by automobile manufacturers in the United States and elsewhere;

**REDACTED**

- (e) submitting bids, price quotations, and price adjustments to automobile manufacturers in the United States and elsewhere in accordance with the agreements reached;
- (f) selling certain automotive parts to automobile manufacturers in the United States and elsewhere at collusive and noncompetitive prices;
- (g) accepting payment for certain automotive parts sold to automobile manufacturers in the United States and elsewhere at collusive and noncompetitive prices;
- (h) engaging in meetings, conversations, and communications in the United States and elsewhere for the purpose of monitoring and enforcing adherence to the agreed-upon bid-rigging and price-fixing scheme;
- (i) employing measures to keep their conduct secret, including, but not limited to, using code names and meeting at remote locations.

147. With respect to the obstruction of justice count, the Mitsuba Information charged as follows:

In or about February 2010, Executive A, acting on Defendant's behalf, knowingly altered, destroyed, mutilated, concealed, covered up, falsified and made false entries in records, documents and tangible objects with the intent to impede, obstruct, and influence the investigation and proper administration of a matter within the jurisdiction of a department and agency of the United States, to wit, an investigation by the FBI and the United States Department of Justice of possible violations of U.S. antitrust law, in relation to and contemplation of such matter and case, and furthermore did order and command other employees of the Defendant to do so, in violation of 18 U.S.C. § 1519.

After becoming aware of the FBI search of Defendant's co-conspirator's U.S. offices, Executive A informed certain of his subordinates employed at the U.S. subsidiary of Defendant about the FBI search, and instructed such subordinates, as well as other employees of Defendant, to locate, conceal and destroy documents

**REDACTED**

and electronic files that were likely to contain evidence of antitrust crimes in the United States and elsewhere.

Executive A concealed and destroyed documents and electronic files in his possession, custody and control in the Eastern District of Michigan that were likely to contain evidence of antitrust crimes in the United States and elsewhere. Certain of Executive A's subordinates and other employees of Defendant took acts in the Eastern District of Michigan and elsewhere to endeavor to conceal and destroy such documents and electronic files in the possession, custody and control of Defendant, and did conceal and destroy such documents and electronic files.

**Defendant Mitsubishi Electric Corporation Pleads Guilty to Price-Fixing**

148. On September 26, 2013, the DOJ announced that Defendant Mitsubishi Electric Corporation agreed to pay a \$190 million criminal fine and plead guilty to a one-count criminal Information charging it with participating in a combination and conspiracy to suppress and eliminate competition in the automotive parts industry by agreeing to rig bids for, and to fix, stabilize, and maintain the prices of, certain automotive parts sold to automobile manufacturers, including Ford Motor Company, General Motors LLC, Chrysler Group LLC, Fuji Heavy Industries Ltd., Nissan Motor Company, Ltd, Honda Motor Company, Ltd., and certain of their subsidiaries in the United States and elsewhere, from at least as early as January 2000 through at least February 2010, in violation of the Sherman Antitrust Act, 15 U.S.C. § 1. For purposes of Mitsubishi Electric Corporation's plea agreement, "automotive parts" are defined to include, among other products, fuel injections, fuel pumps, MAP sensors, purge control valves, and throttle bodies.

149. According to the Information filed, Defendant Mitsubishi Electric Corporation and its co-conspirators carried out the automotive parts combination and conspiracy by, among other things, the following:

**REDACTED**

- (a) participating in meetings, conversations, and communications in the United States and elsewhere to discuss the bids and price quotations to be submitted to automobile manufacturers in the United States and elsewhere;
- (b) agreeing, during those meetings, conversations, and communications, on bids and price quotations to be submitted to automobile manufacturers in the United States and elsewhere;
- (c) agreeing, during those meetings, conversations, and communications, to allocate the supply of certain automotive parts sold to automobile manufacturers in the United States and elsewhere;
- (d) agreeing, during those meetings, conversations, and communications, to coordinate price adjustments requested by automobile manufacturers in the United States and elsewhere;
- (e) submitting bids, price quotations, and price adjustments to automobile manufacturers in the United States and elsewhere in accordance with the agreements reached;
- (f) selling certain automotive parts to automobile manufacturers in the United States and elsewhere at collusive and noncompetitive prices;
- (g) accepting payment for certain automotive parts sold to automobile manufacturers in the United States and elsewhere at collusive and noncompetitive prices;
- (h) engaging in meetings, conversations, and communications in the United States and elsewhere for the purpose of monitoring and enforcing adherence to the agreed-upon bid-rigging and price-fixing scheme;

**REDACTED**

- (i) employing measures to keep their conduct secret, including, but not limited to, using code names and meeting at remote locations.

**Defendant Aisan Industry Co. Pleads Guilty to Price-Fixing Certain Automotive Parts**

150. On February 3, 2014, the DOJ announced that Defendant Aisan Industry Co., Ltd. agreed to pay a \$6.86 million criminal fine and plead guilty to a one-count criminal Information charging it with participating in a conspiracy to suppress and eliminate competition by agreeing to rig bids for, and to fix, stabilize, and maintain the prices of electronic throttle bodies sold to Nissan Motor Co., Ltd. and certain of its subsidiaries in the United States and elsewhere, from at least as early as October 2003 until at least February 2010 in violation of the Sherman Antitrust Act, 15 U.S.C. § 1. According to the Information filed, Defendant Aisan Industry Co., Ltd. and its co-conspirators carried out the electronic throttle bodies conspiracy by:

- (a) participating in meetings, conversations, and communications to discuss the bids and price quotations to be submitted to Nissan in the United States and elsewhere;
- (b) agreeing, during those meetings, conversations, and communications, on bids and price quotations to be submitted to Nissan in the United States and elsewhere;
- (c) agreeing, during those meetings, conversations, and communications, to allocate RFQs for the supply of electronic throttle bodies sold to Nissan in the United States and elsewhere;
- (d) agreeing, during those meetings, conversations, and communications, to coordinate price adjustments requested by Nissan in the United States and elsewhere;

**REDACTED**

- (e) submitting bids, price quotations, and price adjustments to Nissan in the United States and elsewhere in accordance with the agreements reached;
- (f) selling electronic throttle bodies to Nissan in the United States and elsewhere at collusive and noncompetitive prices;
- (g) accepting payment for electronic throttle bodies sold to Nissan in the United States and elsewhere at collusive and noncompetitive prices; and
- (h) engaging in meetings, conversations, and communications for the purpose of monitoring and enforcing adherence to the agreed-upon bid-rigging and price-fixing scheme.

**D. Likely Existence of a Cooperating Defendant**

151. The Antitrust Criminal Penalty Enhancement and Reform Act (“ACPERA”) provides leniency benefits for a participant in a price-fixing conspiracy that voluntarily discloses its conduct to the DOJ. In most recent cases in which guilty pleas for price-fixing conduct have been obtained, there has been a cooperating party that has been accepted into the DOJ’s ACPERA program as an “amnesty applicant.” One of the leniency benefits for a conspirator that is accepted into the ACPERA program is that it is not charged with a criminal offense and is not required to plead guilty to criminal charges.

152. In light of the multiple guilty pleas in this case, in related automotive parts antitrust cases and the DOJ’s ongoing investigation into the industry, it is reasonable for this Court to infer that there is an ACPERA “amnesty applicant” in this case.

**E. Additional Criminal Pleadings in the Automotive Parts Industry**

153. On September 29, 2011, the DOJ announced that Furukawa Electric Co. Ltd. had agreed to plead guilty and to pay a \$200 million criminal fine for its role in a criminal price-

**REDACTED**

fixing and bid-rigging conspiracy involving the sale of automotive wire harnesses and related products to automobile manufacturers.

154. In the press release announcing the fine against Furukawa Electric Co. Ltd., Sharis A. Pozen, then the Acting Assistant Attorney General in charge of the DOJ's Antitrust Division, said that "[a]s a result of this international price-fixing and bid-rigging conspiracy, automobile manufacturers paid noncompetitive and higher prices for parts in cars sold to U.S. consumers." Ms. Pozen also stated that "[t]his cartel harmed an important industry in our nation's economy, and the Antitrust Division with the Federal Bureau of Investigation will continue to work together to ensure that these kinds of conspiracies are stopped." The press release also quoted FBI's Special Agent in Charge Andrew G. Arena, who said that "[w]hen companies partner to control and price fix bids or contracts, it undermines the foundation of the United States' economic system," and that "[t]he FBI is committed to aggressively pursuing any company involved in antitrust crimes."

155. On January 30, 2012, the DOJ announced that Yazaki Corporation agreed to plead guilty and to pay a \$470 million criminal fine and DENSO Corporation, as stated above, had agreed to plead guilty and to pay a \$78 million criminal fine for their respective involvement in multiple price-fixing and bid-rigging conspiracies in the sale of automotive parts to automobile manufacturers in the United States. According to the three-count criminal Information filed against Yazaki, it engaged in three separate conspiracies: (i) to rig bids for and to fix, stabilize, and maintain the prices of, automotive wire harnesses and related products sold to certain automobile manufacturers in the United States and elsewhere; (ii) to rig bids for and to fix, stabilize, and maintain the prices of, instrument panel clusters sold to certain automobile manufacturers in the United States and elsewhere; and (iii) to fix, stabilize, and maintain the

**REDACTED**

prices of fuel senders sold to an automobile manufacturer in the United States and elsewhere. According to the two-count felony charge against Defendant DENSO Corporation, it engaged in conspiracies to rig bids for, and to fix, stabilize, and maintain the prices of, ECUs and HCPs sold to an automobile manufacturer in the United States and elsewhere.

156. In the press release announcing the fines against Yazaki Corporation, its executives, and Defendant DENSO Corporation, Ms. Pozen vowed to continue the investigation into “pernicious cartel conduct that results in higher prices to American consumers . . . .” In the same press release, Special Agent in Charge Andrew G. Arena said that “[t]his criminal activity has a significant impact on the automotive manufacturers in the United States, Canada, Japan and Europe and has been occurring for at least a decade. The conduct had also affected commerce on a global scale in almost every market where automobiles are manufactured and/or sold[.]”

157. Ms. Pozen said there is no doubt **consumers** were hurt financially by the automotive wire harness price-fixing conspiracy. She further stated: “By rigging bids on wiring harnesses . . . the three companies inflated what some of their auto manufacturer clients paid, and indirectly, what consumers paid for some cars.”

158. On April 3, 2012, the DOJ announced that G.S. Electech, Inc. agreed to plead guilty and to pay a \$2.75 million criminal fine for its role in a conspiracy to rig bids for, and to fix, stabilize, and maintain the prices of, speed sensor wire assemblies used on antilock brake systems sold to an automobile manufacturer in the United States and elsewhere.

159. On April 23, 2012, the DOJ announced that Fujikura Ltd. had agreed to plead guilty and to pay a \$20 million criminal fine for its role in a conspiracy to rig bids for, and to fix, stabilize, and maintain the prices of, automotive wire harnesses and related products sold to an automobile manufacturer in the United States and elsewhere.



**REDACTED**

160. On June 6, 2012, the DOJ announced that Autoliv Inc. agreed to plead guilty to a two-count criminal Information and to pay a \$14.5 million criminal fine for its involvement in a combination and conspiracy to suppress competition in the automotive parts industry by (i) agreeing to rig bids for, and to fix, stabilize, and maintain the prices of, certain seatbelts sold to a Japanese automobile manufacturer; and (ii) agreeing to rig bids for, and to fix, stabilize, and maintain the prices of, certain seatbelts, airbags, and/or steering wheels sold to a Japanese automobile manufacturer.

161. On July 30, 2012, the DOJ announced that TRW Deutschland Holding GmbH agreed to plead guilty and to pay a \$5.1 million criminal fine for its involvement in a combination and conspiracy, through its employees, including high level employees of its wholly-owned subsidiaries, to suppress and eliminate competition in the automotive parts industry by agreeing to rig bids for, and to fix, stabilize, and maintain the prices of seatbelts, airbags and steering wheels sold to two German automobile manufacturers in the United States and elsewhere.

162. On August 28, 2012, the DOJ announced that Nippon Seiki Co. Ltd. agreed to plead guilty and to pay a \$1 million criminal fine for its involvement in a combination and conspiracy to suppress competition in the automotive parts industry by agreeing to rig bids for, and to fix, stabilize, and maintain the prices of, instrument panel clusters sold to an automobile manufacturer in in the United States and elsewhere.

163. On October 30, 2012, the DOJ announced that Tokai Rika Co. Ltd. agreed to plead guilty and to pay a \$17.7 million criminal fine for its involvement in a conspiracy to rig bids for, and to fix, stabilize, and maintain the prices of, HCPs sold to Toyota Motor Corporation and Toyota Motor Engineering & Manufacturing North America, Inc. in the United States and

**REDACTED**

elsewhere. Tokai Rika also agreed to plead guilty to a charge of obstruction of justice related to the investigation of the antitrust violation.

164. On February 15, 2013, Scott Hammond, the Deputy Assistant Attorney General in the DOJ's Antitrust Division, discussed the DOJ's ongoing automotive parts investigation in a Thomson Reuters article. He said "[t]he investigation is broader than what we've announced so far . . . . [The investigation] is still very much ongoing, but it already appears to be the biggest criminal antitrust investigation that we've ever encountered. *I say the biggest with respect to the impact on U.S. businesses and consumers, and the number of companies and executives that are subject to the investigation.*" (emphasis added).

165. On July 16, 2013, the DOJ announced that Diamond Electric Mfg. Co. Ltd. agreed to plead guilty and to pay a \$19 million criminal fine for its involvement in a combination and conspiracy to suppress competition in the automotive parts industry by agreeing to rig bids for, and to fix, stabilize, and maintain the prices of, ignition coils sold to automobile manufacturers in the United States and elsewhere.

166. In the press release announcing the fine against Diamond Electric Mfg. Co. Ltd., Robert D. Foley III, Agent in Charge, FBI Detroit Division said "[t]hose who engage in price fixing, bid rigging and other fraudulent schemes harm the automotive industry by driving up costs for vehicle makers and buyers."

167. On July 18, 2013, Panasonic Corporation agreed to plead guilty and to pay a \$45.8 million criminal fine for its role in a conspiracy to fix prices of various automotive parts including high intensity discharge ("HID") ballasts, switches and steering angle sensors installed in automobiles sold in the United States and elsewhere.

**REDACTED**

168. On September 26, 2013, nine additional Japanese automotive suppliers, including Defendant Hitachi Automotive Systems Ltd., agreed to plead guilty to conspiracy charges and pay more than \$740 million in criminal fines for their roles in rigging the prices of more than 30 different automotive products:

- (a) Defendant Hitachi Automotive Systems Ltd. agreed to plead guilty and to pay a \$195 million criminal fine for its participation in a conspiracy to rig bids for, and to fix, stabilize and maintain the prices of automotive parts, including, among others, air flow meters, fuel injection systems, and electronic throttle bodies, sold to automobile manufacturers in the United States and elsewhere;
- (b) Defendant Mitsuba Corporation agreed to plead guilty and to pay a \$135 million criminal fine for its participation in a conspiracy to rig bids for, and to fix, stabilize and maintain the prices of certain automotive parts sold to automobile manufacturers in the United States and elsewhere. For purposes of Mitsuba's plea agreement, "automotive parts" are defined to include, among other automotive products, electric throttle motors and fuel pumps. Mitsuba also agreed to plead guilty to one count of obstruction of justice because of the company's efforts to destroy evidence ordered by a high-level U.S.-based executive after learning of the U.S. investigation of collusion in the automotive parts industry;
- (c) Defendant Mitsubishi Electric Corporation agreed to plead guilty and to pay a \$190 million criminal fine for its participation in a conspiracy to rig bids for, and to fix, stabilize and maintain the prices of certain automotive parts sold to automobile manufacturers in the United States and elsewhere. For purposes of Mitsubishi Electric Corporation's plea agreement, "automotive parts" are defined

**REDACTED**

to include, among other automotive products, fuel injectors, fuel pumps, MAP Sensors, and throttle bodies;

(d) Mitsubishi Heavy Industries Ltd. agreed to plead guilty and to pay a \$14.5 million criminal fine for its participation in a conspiracy to rig bids for, and to fix, stabilize and maintain the prices of compressors and condensers sold to automobile manufacturers in the United States and elsewhere;

(e) T.RAD Co. Ltd. agreed to plead guilty and to pay a \$13.75 million criminal fine for its participation in a conspiracy to rig bids for, and to fix, stabilize and maintain the prices of radiators and automatic transmission fluid warmers (“ATF warmers”) sold to Toyota Motor Corporation in the United States and elsewhere;

(f) Valeo Japan Co. Ltd. agreed to plead guilty and to pay a \$13.6 million criminal fine for its participation in a conspiracy to allocate the supply of, rig bids for, and to fix, stabilize and maintain the prices of air conditioning systems sold to automobile manufacturers in the United States and elsewhere;

(g) JTEKT Corporation agreed to plead guilty and to pay a \$103.27 million criminal fine for its participation in a conspiracy to allocate markets, to rig bids for, and to fix, stabilize and maintain the prices of bearings and electric powered steering assemblies sold to automobile manufacturers in the United States and elsewhere;

(h) NSK Ltd. agreed to plead guilty and to pay a \$68.2 million criminal fine for its participation in a conspiracy to allocate markets, to rig bids for, and to fix,

**REDACTED**

stabilize and maintain the prices of bearings sold to an automobile manufacturer in the United States and elsewhere; and

(i) Yamashita Rubber Co. Ltd. agreed to plead guilty and to pay an \$11 million criminal fine for its participation in a conspiracy to rig bids for, and to fix, raise and maintain the prices of automotive anti-vibration rubber products sold in the United States and elsewhere to automobile manufacturers.

169. On the same day, September 26, 2013, United States Attorney General Eric Holder presented the DOJ's most recent findings in the ongoing automotive parts investigation. He stated "[t]hese international price-fixing conspiracies affected more than \$5 billion in automotive parts sold to U.S. car manufacturers. In total, more than 25 million cars purchased by American consumers were affected by the illegal conduct." Attorney General Holder also described how the conspiracies worked: "[c]ompany executives met face to face in the United States and Japan – and talked on the phone – to reach collusive agreements to rig bids, fix prices and allocate the supply of auto parts sold to U.S. car companies. In order to keep their illegal conduct secret, they used code names and met in remote locations. Then they followed up with each other regularly to make sure the collusive agreements were being adhered to." Attorney General Holder explained that the automotive parts conspiracies "targeted U.S. manufacturing, U.S. businesses and U.S. consumers. As a result of these conspiracies, Americans paid more for their cars."

170. The diagram below, which was prepared by the DOJ, illustrates the September 26, 2013 guilty pleas and the corresponding automotive parts to which the various manufacturers have admitted price-fixing.

REDACTED

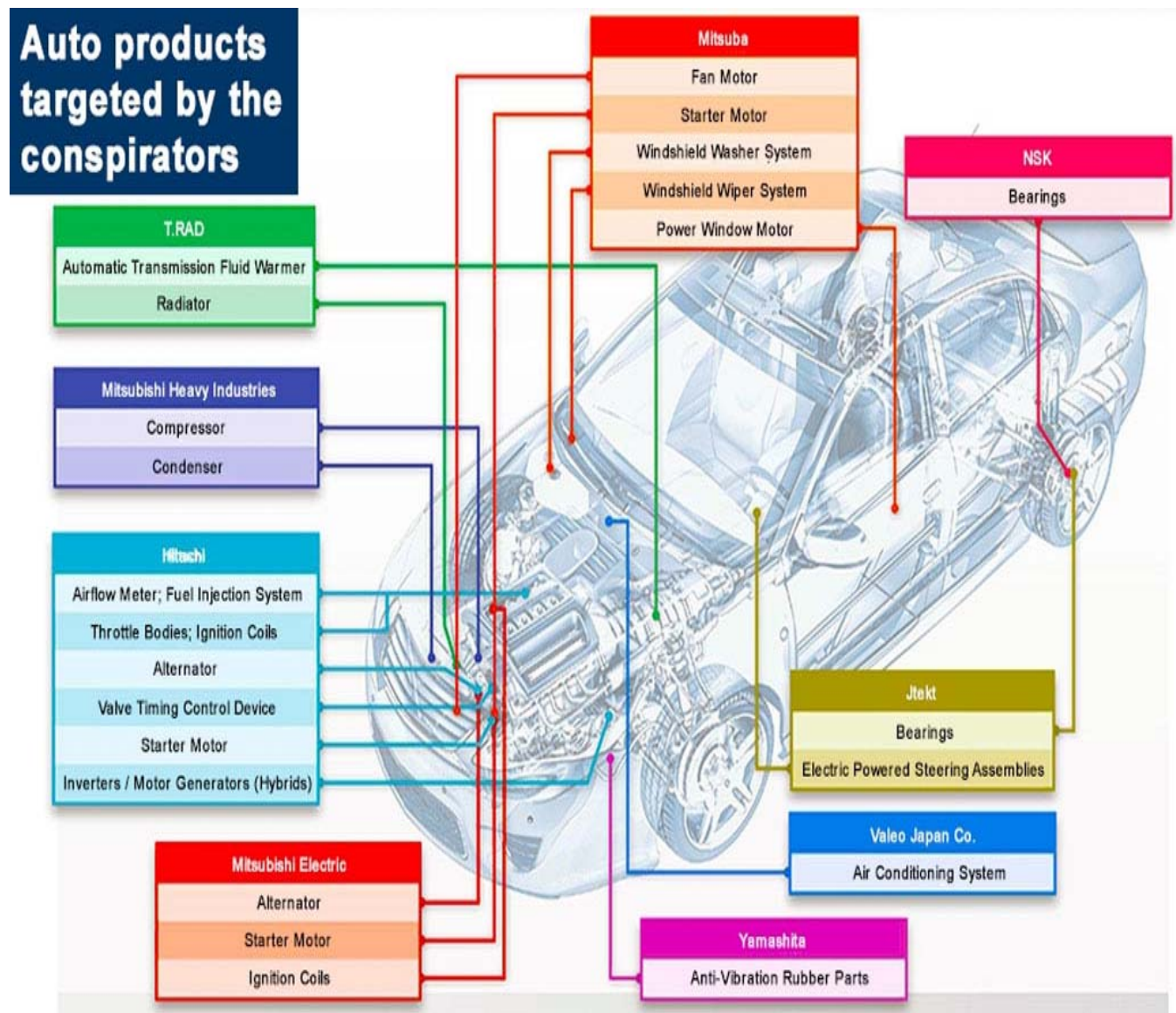

171. On October 9, 2013, Takata Corporation announced that it agreed to pay \$71.3 million to settle antitrust charges brought by the United States federal prosecutors for its role in a conspiracy to price-fix seatbelts.

172. On November 26, 2013, the DOJ announced that Toyo Tire & Rubber Co. Ltd. agreed to plead guilty and to pay a \$120 million criminal fine for its role in two separate conspiracies. Toyo Tire & Rubber Co. Ltd. engaged in a conspiracy to suppress and eliminate competition in the automotive parts industry by agreeing to allocate sales of, to rig bids for, and

**REDACTED**

to fix, raise, and maintain the prices of, automotive anti-vibration rubber products sold to Toyota Motor Corporation, Nissan Motor Corporation, Fuji Heavy Industries, Ltd., and certain of their subsidiaries, affiliates and suppliers in the United States and elsewhere, and by agreeing to allocate sales of, and to fix, raise, and maintain the prices of, automotive constant-velocity-joint boot products sold to GKN plc and its subsidiaries in the United States and elsewhere.

173. On November 27, 2013, the DOJ announced that Stanley Electric Co. Ltd. agreed to plead guilty and to pay a \$1.44 million criminal fine for its participation in a conspiracy to fix prices of automotive HID lamp ballasts installed in automobiles sold in the United States and elsewhere.

174. On January 16, 2014, the DOJ announced that Koito Manufacturing Co. Ltd. agreed to plead guilty and to pay a \$56.6 million criminal fine for its roles in separate price-fixing conspiracies involving automobile lighting fixtures and automotive HID lamp ballasts installed in cars sold in the United States and elsewhere.

175. On February 3, 2014, the DOJ announced that Defendant Aisan Industry Co. Ltd. agreed to plead guilty and to pay a \$6.86 million criminal fine for its role in a price-fixing conspiracy involving electronic throttle bodies sold to an automobile manufacturer in the United States and elsewhere.

176. On February 13, 2014, the DOJ announced that Bridgestone Corp. agreed to plead guilty and to pay a \$425 million criminal fine for its role in a conspiracy to fix prices of automotive anti-vibration rubber parts installed in automobiles sold in the United States and elsewhere.

177. On April 23, 2014, the DOJ announced that Showa Corp. agreed to plead guilty and to pay a \$19.9 million criminal fine for its role in a conspiracy to fix prices and rig bids for



**REDACTED**

pinion-assist type electric powered steering assemblies installed in cars sold in the United States and elsewhere.

178. On August 19, 2014, the DOJ announced that NGK Sparkplug Co. Ltd. agreed to plead guilty and to pay a \$52.1 million criminal fine for its role in a conspiracy to fix prices and rig bids for spark plugs, standard oxygen sensors, and air fuel ratio sensors installed in cars sold to automobile manufacturers in the United States and elsewhere.

179. On September 29, 2014, the DOJ announced that Toyoda Gosei Co. Ltd. agreed to plead guilty and to pay a \$26 million criminal fine for its involvement in a combination and conspiracy to suppress competition in the automotive parts industry by agreeing to allocate sales of, to rig bids for, and to fix, stabilize, and maintain the prices of certain automotive hoses sold to Toyota in the United States and by agreeing to allocate sales of, to rig bids for, and to fix, stabilize, and maintain the prices of, automotive airbags and steering wheels sold to Subaru and Toyota in the United States and elsewhere.

180. On October 31, 2014, the DOJ announced that Hitachi Metals Ltd. agreed to plead guilty and to pay a \$1.25 million criminal fine for its role in a conspiracy to allocate the sales of, to rig bids for, and to fix, raise, and maintain the prices of automotive brake hose sold to Toyota in the United States and elsewhere.

181. On November 13, 2014, the DOJ announced that Aisin Seiki Co. Ltd. agreed to plead guilty and to pay a \$35.8 million criminal fine for its role in a conspiracy to allocate customers of variable valve timing devices installed in cars sold to automobile manufacturers in the United States and elsewhere.

182. On November 24, 2014, the DOJ announced that Continental Automotive Electronics LLC and Continental Automotive Korea Ltd. agreed to plead guilty and to pay a



**REDACTED**

criminal fine of \$4 million for their roles in a conspiracy to rig bids of instrument panel clusters installed in vehicles manufactured and sold in the United States.

183. To date, thirty-two companies and forty-eight executives have been charged in the DOJ's ongoing investigation into price-fixing and bid-rigging in the automotive parts industry. Each of the thirty-two companies has either pleaded guilty or agreed to plead guilty and altogether, they have agreed to pay approximately \$2.4 billion in criminal fines.

184. "This criminal activity has a significant impact on the automotive manufacturers in the United States, Canada, Japan and Europe and has been occurring at least a decade. The conduct had also affected commerce on a global scale in almost every market where automobiles are manufactured and/or sold," said FBI's Special Agent in Charge Andrew G. Arena. "When companies partner to control and price fix bids or contracts, it undermines the foundation of the United States' economic system," Arena also said. "The FBI is committed to aggressively pursuing any company involved in antitrust crimes."

**F. Illustrative Examples**

185. [REDACTED]

186. [REDACTED]

**REDACTED**

[REDACTED]

187. [REDACTED]

[REDACTED]

188. [REDACTED]

[REDACTED]

**REDACTED**

[REDACTED]

189. [REDACTED]

[REDACTED]

190. [REDACTED]

[REDACTED]

**REDACTED**

[REDACTED]

191. [REDACTED]

[REDACTED]

192. [REDACTED]

[REDACTED]

**REDACTED**

[REDACTED]

[REDACTED]

[REDACTED]

193. [REDACTED]

[REDACTED]

[REDACTED]

[REDACTED]

[REDACTED]

[REDACTED]

[REDACTED]

[REDACTED]

[REDACTED]

[REDACTED]

[REDACTED]

[REDACTED]

194. [REDACTED]

[REDACTED]

[REDACTED]

[REDACTED]

[REDACTED]

[REDACTED]

[REDACTED]

[REDACTED]

**REDACTED**

195. [REDACTED]

[REDACTED]

[REDACTED]

[REDACTED]

[REDACTED]

[REDACTED]

[REDACTED]

[REDACTED]

[REDACTED]

[REDACTED]

[REDACTED]

[REDACTED]

196. [REDACTED]

[REDACTED]

[REDACTED]

[REDACTED]

[REDACTED]

[REDACTED]

[REDACTED]

197. [REDACTED]

[REDACTED]

[REDACTED]

[REDACTED]

[REDACTED]

[REDACTED]

[REDACTED]

**REDACTED**

[REDACTED]

[REDACTED]

[REDACTED]

198. [REDACTED]

[REDACTED]

[REDACTED]

[REDACTED]

[REDACTED]

[REDACTED]

[REDACTED]

[REDACTED]

[REDACTED]

199. [REDACTED]

[REDACTED]

[REDACTED]

[REDACTED]

[REDACTED]

[REDACTED]

[REDACTED]

[REDACTED]

[REDACTED]

200. [REDACTED]

[REDACTED]

**REDACTED**

[REDACTED]

201. [REDACTED]

[REDACTED]

**CLASS ACTION ALLEGATIONS**

202. Plaintiffs bring this action on behalf of themselves and as a class action under Rule 23(a) and (b)(2) of the Federal Rules of Civil Procedure, seeking equitable and injunctive relief on behalf of the following class (the “Nationwide Class”):

All persons and entities who, during the Class Period, purchased or leased a new vehicle in the United States not for resale which included one or more Fuel Injection System(s) as a component part, which were manufactured or sold by a Defendant, any current or former subsidiary of a Defendant or any co-conspirator of the Defendants.

203. Plaintiffs also bring this action on behalf of themselves and as a class action under Rule 23(a) and (b)(3) of the Federal Rules of Civil Procedure seeking damages pursuant to state antitrust, unfair competition, and consumer protection laws as well as common law unjust enrichment on behalf of the following class (the “Damages Class”):



**REDACTED**

All persons and entities who, during the Class Period, purchased or leased a new vehicle in the Indirect Purchaser States<sup>2</sup> not for resale which included one or more Fuel Injection System(s) as a component part, which were manufactured or sold by a Defendant, any current or former subsidiary of a Defendant or any co-conspirator of the Defendants.

204. The Nationwide Class and the Damages Class are referred to herein as the “Classes.” Excluded from the Classes are the Defendants, their parent companies, subsidiaries and affiliates, any co-conspirators, federal governmental entities and instrumentalities of the federal government, states and their subdivisions, agencies and instrumentalities, and persons who purchased Fuel Injection Systems directly or for resale.

205. While Plaintiffs do not know the exact number of the members of the Classes, Plaintiffs believe there are (at least) thousands of members in each Class.

206. Common questions of law and fact exist as to all members of the Classes. This is particularly true given the nature of the Defendants’ conspiracy, which was generally applicable to all the members of both Classes, thereby making appropriate relief with respect to the Classes as a whole. Such questions of law and fact common to the Classes include, but are not limited to:

- (a) Whether the Defendants and their co-conspirators engaged in a combination and conspiracy among themselves to fix, raise, maintain or stabilize the prices of Fuel Injection Systems sold in the United States;
- (b) The identity of the participants of the alleged conspiracy;

---

<sup>2</sup> The Indirect Purchaser States are the states listed in the Second and Third Claims for Relief.

**REDACTED**

- (c) The duration of the alleged conspiracy and the acts carried out by Defendants and their co-conspirators in furtherance of the conspiracy;
- (d) Whether the alleged conspiracy violated the Sherman Act, as alleged in the First Claim for Relief;
- (e) Whether the alleged conspiracy violated state antitrust, unfair competition, and/or consumer protection laws, as alleged in the Second and Third Claims for Relief;
- (f) Whether the Defendants unjustly enriched themselves to the detriment of the Plaintiffs and the members of the Classes, thereby entitling Plaintiffs and the members of the Classes to disgorgement of all benefits derived by Defendants, as alleged in the Fourth Claim for Relief;
- (g) Whether the conduct of the Defendants and their co-conspirators, as alleged in this Complaint, caused injury to the business or property of Plaintiffs and the members of the Classes;
- (h) The effect of the alleged conspiracy on the prices of Fuel Injection Systems sold in the United States during the Class Period;
- (i) Whether Plaintiffs and the members of the Classes had any reason to know or suspect the conspiracy, or any means to discover the conspiracy;
- (j) Whether the Defendants and their co-conspirators fraudulently concealed the conspiracy's existence from Plaintiffs and the members of the Classes;
- (k) The appropriate injunctive and related equitable relief for the Nationwide Class; and
- (l) The appropriate class-wide measure of damages for the Damages Class.

**REDACTED**

207. Plaintiffs' claims are typical of the claims of the members of the Classes, and Plaintiffs will fairly and adequately protect the interests of the Classes. Plaintiffs and all members of the Classes are similarly affected by the Defendants' wrongful conduct in that they paid artificially inflated prices for Fuel Injection Systems purchased indirectly from the Defendants and/or their co-conspirators.

208. Plaintiffs' claims arise out of the same common course of conduct giving rise to the claims of the other members of the Classes. Plaintiffs' interests are coincident with, and not antagonistic to, those of the other members of the Classes. Plaintiffs are represented by counsel who are competent and experienced in the prosecution of antitrust and class action litigation.

209. The questions of law and fact common to the members of the Classes predominate over any questions affecting only individual members, including legal and factual issues relating to liability and damages.

210. Class action treatment is a superior method for the fair and efficient adjudication of the controversy, in that, among other things, such treatment will permit a large number of similarly situated persons to prosecute their common claims in a single forum simultaneously, efficiently and without the unnecessary duplication of evidence, effort and expense that numerous individual actions would engender. The benefits of proceeding through the class mechanism, including providing injured persons or entities with a method for obtaining redress for claims that might not be practicable to pursue individually, substantially outweigh any difficulties that may arise in the management of this class action.

211. The prosecution of separate actions by individual members of the Classes would create a risk of inconsistent or varying adjudications, establishing incompatible standards of conduct for the Defendants.

**REDACTED**

**PLAINTIFFS AND THE CLASSES SUFFERED ANTITRUST INJURY**

212. The Defendants' price-fixing conspiracy had the following effects, among others:

- (a) Price competition has been restrained or eliminated with respect to Fuel Injection Systems;
- (b) The prices of Fuel Injection Systems have been fixed, raised, maintained, or stabilized at artificially inflated levels;
- (c) Indirect purchasers of Fuel Injection Systems have been deprived of free and open competition; and
- (d) Indirect purchasers of Fuel Injection Systems paid artificially inflated prices.

213. During the Class Period, Plaintiffs and the members of the Classes paid supra-competitive prices for Fuel Injection Systems. OEMS and automotive dealers passed on inflated prices to Plaintiffs and the members of the Classes. Those overcharges have unjustly enriched Defendants.

214. The markets for Fuel Injection Systems and vehicles are inextricably linked and intertwined because the market for Fuel Injection Systems exists to serve the vehicle market. Without the vehicles, the Fuel Injection Systems have little to no value because they have no independent utility. Indeed, the demand for vehicles creates the demand for Fuel Injection Systems. As stated in the 2010 Annual Report of Lear Corporation, an automotive parts supplier: "Our sales are driven by the number of vehicles produced by the automotive manufacturers, which is ultimately dependent on consumer fleet demand for automotive vehicles."

215. Fuel Injection Systems are identifiable, discrete physical products that remain essentially unchanged when incorporated into a vehicle. As a result, Fuel Injection Systems follow a traceable physical chain of distribution from the Defendants to Plaintiffs and the

**REDACTED**

members of the Classes, and costs attributable to Fuel Injection Systems can be traced through the chain of distribution to Plaintiffs and the members of the Classes.

216. Just as Fuel Injection Systems can be physically traced through the supply chain, so can their price be traced to show that changes in the prices paid by direct purchasers of Fuel Injection Systems affect prices paid by indirect purchasers of new motor vehicles containing Fuel Injection Systems.

217. While even a monopolist would increase its prices when the cost of its inputs increased, the economic necessity of passing through cost changes increases with the degree of competition a firm faces. The OEM and dealer markets for new motor vehicles are subject to vigorous price competition. The OEMs and dealers have thin net margins, and are therefore at the mercy of their component costs, such that increases in the price of components such as Fuel Injection Systems lead to corresponding increases in prices for new motor vehicles at the OEM and dealer levels. When downstream distribution markets are highly competitive, as they are in the case of new motor vehicles containing Fuel Injection Systems as components, overcharges are passed through to ultimate consumers, such as the indirect-purchaser Plaintiffs and members of the Classes.

218. Hence the inflated prices of Fuel Injection Systems in new motor vehicles resulting from Defendants' bid-rigging and price-fixing conspiracy have been passed on to Plaintiffs and the other members of the Classes by OEMs and dealers.

219. The economic and legal literature has recognized that unlawful overcharges in a component normally result in higher prices for products containing that price-fixed component. Two antitrust scholars – Professors Robert G. Harris (Professor Emeritus and former Chair of the Business and Public Policy Group at the Haas School of Business at the University of California

**REDACTED**

at Berkeley) and the late Lawrence A. Sullivan (Professor of Law Emeritus at Southwestern Law School and author of the Handbook of the Law of Antitrust) – have observed that “in a multiple-level chain of distribution, passing on monopoly overcharges is not the exception: it is the rule.”<sup>3</sup>

220. As Professor Jeffrey K. MacKie-Mason (Arthur W. Burks Professor for Information and Computer Science and Professor of Economics and Public Policy at the University of Michigan), an expert who presented evidence in a number of indirect purchaser cases involving Microsoft Corporation, said (in a passage quoted in the judicial decision in that case granting class certification):

As is well known in economic theory and practice, at least some of the overcharge will be passed on by distributors to end consumers. When the distribution markets are highly competitive, as they are here, all or nearly the entire overcharge will be passed on through to ultimate consumers...Both of Microsoft’s experts also agree upon the economic phenomenon of cost pass through, and how it works in competitive markets. This general phenomenon of cost pass through is well established in antitrust laws and economics as well.<sup>4</sup>

221. The purpose of the conspiratorial conduct of Defendants and their co-conspirators was to raise, fix, rig or stabilize the price of Fuel Injection Systems and, as a direct and foreseeable result, the price of new motor vehicles containing Fuel Injection Systems. Economists have developed techniques to isolate and understand the relationship between one “explanatory” variable and a “dependent” variable in those cases when changes in the dependent variable are explained by changes in a multitude of variables, even when all such variables may

---

<sup>3</sup> Robert G. Harris & Lawrence A. Sullivan, *Passing on the Monopoly Overcharge: A Comprehensive Policy Analysis*, 128 U. PA. L. REV. 268, 275 (1979).

<sup>4</sup> Order re: Class Certification at 13-14, *Coordination Proceedings Special Title (Rule 1550(b)) Microsoft I-V Cases*, No. J.C.C.P. No. 4106, (Cal. Sup. Ct. Aug. 29, 2000).

**REDACTED**

be changing simultaneously. That analysis - called regression analysis - is commonly used in the real world and in litigation to determine the impact of a price increase on one cost in a product (or service) that is an assemblage of costs. Thus, it is possible to isolate and identify only the impact of an increase in the price of Fuel Injection Systems on prices for new motor vehicles even though such products contain a number of other components whose prices may be changing over time. A regression model can explain how variation in the price of Fuel Injection Systems affects changes in the price of new motor vehicles. In such models, the price of Fuel Injection Systems would be treated as an independent or explanatory variable. The model can isolate how changes in the price of Fuel Injection Systems impact the price of new motor vehicles containing Fuel Injection Systems while controlling for the impact of other price-determining factors.

222. The precise amount of the overcharge impacting the prices of new motor vehicles containing Fuel Injection Systems can be measured and quantified. Commonly used and well-accepted economic models can be used to measure both the extent and the amount of the supra-competitive charge passed through the chain of distribution. Thus, the economic harm to Plaintiffs and class members can be quantified.

223. In addition to the regression analysis discussed above demonstrating impact on consumers, the Department of Justice's Antitrust Division, which has been investigating this cartel for some time, **has concluded that there is "no doubt" that consumers were hurt financially.** Sharis A. Pozen, then Acting Assistant Attorney General in charge of the Department of Justice's Antitrust Division said: "By rigging bids . . . [automotive parts manufacturers engaged in a price-fixing conspiracy] inflated what some of their auto manufacturing clients paid, and indirectly, what consumers paid for some cars." She also explained that "[a]s a result of this international price-fixing and bid-rigging conspiracy,

**REDACTED**

automobile manufacturers paid noncompetitive and higher prices for parts in cars sold to U.S. consumers.” Ms. Pozen also stated that “[t]his cartel harmed an important industry in our nation’s economy, and the Antitrust Division with the Federal Bureau of Investigation will continue to work together to ensure that these kinds of conspiracies are stopped.” In a separate press statement, Ms. Pozen vowed to continue the investigation into “pernicious cartel conduct that results in higher prices to American consumers . . . .”

224. On February 15, 2013, Scott Hammond, the Deputy Assistant Attorney General in the DOJ’s Antitrust Division, discussed the DOJ’s ongoing automotive parts investigation in a Thomson Reuters article. He said “[t]he investigation is broader than what we’ve announced so far . . . . [The investigation] is still very much ongoing, but it already appears to be the biggest criminal antitrust investigation that we’ve ever encountered. ***I say the biggest with respect to the impact on U.S. businesses and consumers, and the number of companies and executives that are subject to the investigation.***” (emphasis added).

225. On September 26, 2013, United States Attorney General Eric Holder in the Antitrust Division presented the DOJ’s then most recent findings in the ongoing automotive parts investigation. He stated “[t]hese international price fixing conspiracies affected more than \$5 billion in automobile parts sold to U.S. car manufacturers. In total, more than 25 million cars purchased by American consumers were affected by the illegal conduct.” Attorney General Holder also described how the conspiracies worked: “[c]ompany executives face to face in the United States and Japan – and talked on the phone – to reach collusive agreements to rig bids, fix prices and allocate the supply of auto parts sold to U.S. car companies. In order to keep their illegal conduct secret, they used code names and met in remote locations. Then they followed up with each other regularly to make sure the collusive agreements were being adhered to.”



**REDACTED**

Attorney General Holder explained that the automotive parts conspiracies “targeted U.S. manufacturing, U.S. businesses and U.S. consumers. As a result of these conspiracies, Americans paid more for their cars.”

226. On May 25, 2014, news sources reported that Brent Snyder, a deputy assistant attorney general in the Antitrust Division, said with respect to the automotive parts conspiracies, “[i]t’s a very, very safe assumption that U.S. consumers paid more, and sometimes significantly more, for their automobiles as a result of this conspiracy.”

227. By reason of the violations of the antitrust law alleged herein, Plaintiffs and the members of the Classes have sustained injury to their businesses or property, having paid higher prices for Fuel Injection Systems than they would have paid in the absence of the Defendants’ illegal contract, combination, or conspiracy, and, as a result, have suffered damages in an amount presently undetermined. This is an antitrust injury of the type that the antitrust laws were meant to punish and prevent.

**PLAINTIFFS’ CLAIMS ARE NOT BARRED BY THE STATUTE OF LIMITATIONS**

**A. The Statute of Limitations Did Not Begin to Run Because Plaintiffs Did Not And Could Not Discover Their Claims**

228. Plaintiffs repeat and re-allege the allegations set forth above.

229. Plaintiffs and the members of the Classes had no knowledge of the combination or conspiracy alleged herein, or of facts sufficient to place them on inquiry notice of the claims set forth herein, until (at the earliest) September 26, 2013, the date that the DOJ publicly announced Defendant Hitachi Automotive Systems, Ltd.’s anticipated guilty plea.<sup>5</sup>

---

<sup>5</sup> Plaintiffs and members of the Classes had no knowledge of the combination or conspiracy alleged herein, or of facts sufficient to place them on inquiry notice of the claims set forth herein, *(continued)*

**REDACTED**

230. Plaintiffs and the members of the Classes are purchasers who purchased or leased vehicles containing Fuel Injection Systems. They had no direct contact or interaction with the Defendants and had no means from which they could have discovered the combination and conspiracy described in this Complaint before September 26, 2013, the date that the DOJ publicly announced Defendant Hitachi Automotive Systems, Ltd.'s anticipated guilty plea.

231. No information in the public domain was available to Plaintiffs and members of the Classes prior to September 26, 2013, the date that the DOJ publicly announced Hitachi Automotive Systems, Ltd.'s anticipated guilty plea, that revealed sufficient information to suggest that the Defendants were involved in a criminal conspiracy to price-fix and rig bids for Fuel Injection Systems. Plaintiffs and the members of the Classes had no means of obtaining any facts or information concerning any aspect of the Defendants' dealings with OEMs or other direct purchasers, much less the fact that they and their co-conspirators had engaged in the combination and conspiracy alleged herein.

232. For these reasons, the statute of limitations as to Plaintiffs' and the Classes' claims did not begin to run, and has been tolled with respect to the claims that Plaintiffs and members of the Classes have alleged in this Complaint.

---

*(continued)*

until (at the earliest), November 13, 2014 for Keihin, Mikuni, and Bosch, and November 21 for Maruyasu and DENSO International Korea Corporation, the dates that Plaintiffs were provided with confidential information regarding these Defendants' participation in the combination or conspiracy alleged herein. No information in the public domain was available to the Plaintiffs and the members of the Classes prior to November 13, 2014 and November 21, 2014 that revealed sufficient information to suggest that the aforementioned Defendants were involved in the combination or conspiracy alleged herein. Therefore, the statute of limitations did not begin to run because Plaintiffs and members of the Classes did not and could not discover their claims, or in the alternative, because fraudulent concealment tolled the statute of limitations, until November 13, 2014 with respect to Keihin, Mikuni, and Bosch and until November 21, 2014 with respect to Maruyasu and DENSO International Korea Corporation.

**REDACTED**

**B. Fraudulent Concealment Tolled the Statute of Limitations**

233. In the alternative, application of the doctrine of fraudulent concealment tolled the statute of limitations on the claims asserted herein by Plaintiffs and the Classes. Plaintiffs and the members of the Classes did not discover, and could not discover through the exercise of reasonable diligence, the existence of the conspiracy alleged herein until September 26, 2013, the date that the DOJ publicly announced Defendant Hitachi Automotive Systems, Ltd.'s anticipated guilty plea.<sup>6</sup>

234. Before that time, Plaintiffs and the members of the Classes were unaware of the Defendants' unlawful conduct, and did not know before then that they were paying supra-competitive prices for Fuel Injection Systems throughout the United States during the Class Period. No information, actual or constructive, was ever made available to Plaintiffs and members of the Classes that even hinted to Plaintiffs that they were being injured by the Defendants' unlawful conduct.

235. The affirmative acts of Defendants alleged herein, including acts in furtherance of the conspiracy, were wrongfully concealed and carried out in a manner that precluded detection.

236. Specifically, as Attorney General Holder explained in connection with the DOJ's globally coordinated investigation into price-fixing in the Automotive parts industry, "[i]n order to keep their illegal conduct secret, [Defendants] used code names and met in remote locations."

237. As stated in the Information filed against Defendant Hitachi Automotive Systems, Ltd., the Defendants and their co-conspirators employed "measures to keep their conduct secret, including, but not limited to, using code names and meeting at remote locations."

---

<sup>6</sup> See footnote five.

**REDACTED**

238. A former executive of Defendant DENSO, Kazuaki Fujitani, pleaded guilty to a charge of obstruction of justice in which he admitted that he “corruptly destroyed and concealed records and documents by deleting numerous emails and electronic files from the period August 1, 2009 to January 4, 2010” for a related automotive part.

239. In addition, two employees of Mitsubishi Electric Corporation, Minoru Kurisaki and Hideyuki Saito were charged by the DOJ with knowingly conspiring to obstruct justice by destroying documents and corruptly persuading, and attempting to persuade others, to destroy documents related to an official proceeding, grand jury investigation, and U.S. agency investigation. The DOJ also charged Hideyuki Saito with obstruction of justice by knowingly and corruptly persuading or attempting to persuade other employees of Mitsubishi Electric Corporation to destroy or conceal paper documents and delete electronic data that may contain evidence of antitrust crimes in the United States and elsewhere with the intent to impair the objects’ availability and integrity for use in official proceedings.

240. Defendant Mitsuba Corporation also pleaded guilty to a charge of obstruction of justice in which it explicitly admitted to “altering, destroying, mutilating, concealing, covering up, falsifying and making false entries in documents and tangible objects with the intent to impede, obstruction, and influence” the DOJ’s investigation into the price-fixing of several automotive parts, including Fuel Injection Systems. According to Mitsuba Corporation’s plea agreement, in February 2010, three of Mitsuba’s senior executives learned that the offices of a co-conspirator had been searched by law enforcement authorities in connection with an investigation of possible antitrust violations, and they directed their subordinates and other employees to “conceal and destroy documents and electronic files” in both the United States and

**REDACTED**

Japan. Mitsuba Corporation's plea agreement confirmed that such evidence was concealed and destroyed.

241. By its very nature, the Defendants' anticompetitive conspiracy and unlawful combinations were inherently self-concealing. Fuel Injection Systems are not exempt from antitrust regulation and, thus, before September 26, 2013, Plaintiffs reasonably considered the Fuel Injection Systems industry to be a competitive industry. Defendants met and communicated in secret and agreed to keep the facts about their collusive conduct from being discovered by any member of the public or by the OEMs and other direct purchasers with whom they did business. Accordingly, a reasonable person under the circumstances would not have been alerted to begin to investigate the legitimacy of the Defendants' Fuel Injection System prices before September 26, 2013.

242. Plaintiffs and the members of the Classes could not have discovered the alleged combination or conspiracy at an earlier date by the exercise of reasonable diligence because of the deceptive practices and techniques of secrecy employed by the Defendants and their co-conspirators to avoid detection of, and fraudulently conceal, their contract, combination, or conspiracy.

243. Throughout the course of the conspiracy, the Defendants met and communicated in secret in order to conceal their conspiracy from the public and avoid detection thereof. Above and beyond their acts in furtherance of the conspiracy, such as acts of bid rigging, Defendants engaged in surreptitious activity such as using code names and meeting at private residences or remote locations. The conspirators also coordinated their pricing in a manner to avoid detection by the OEMs. The exact dates and times of these meetings are within the knowledge of the

**REDACTED**

Defendants, including those Defendants and executives of those Defendants who have pleaded guilty to criminal violations of the Sherman Act.

244. Because the alleged conspiracy was both self-concealing and affirmatively concealed by Defendants and their co-conspirators, Plaintiffs and members of the Classes had no knowledge of the alleged conspiracy, or of any facts or information that would have caused a reasonably diligent person to investigate whether a conspiracy existed, until September 26, 2013, the date that the DOJ publicly announced Hitachi Automotive Systems, Ltd.'s anticipated guilty plea.

245. For these reasons, the statute of limitations applicable to Plaintiffs' and the Classes' claims was tolled and did not begin to run until September 26, 2013.

**FIRST CLAIM FOR RELIEF**  
**Violation of Section 1 of the Sherman Act**  
**(on behalf of Plaintiffs and the Nationwide Class)**

246. Plaintiffs incorporate by reference the allegations in the preceding paragraphs.

247. The Defendants and unnamed co-conspirators entered into and engaged in a contract, combination, or conspiracy an unreasonable restraint of trade in violation of Section 1 of the Sherman Act (15 U.S.C. § 1).

248. The acts done by the Defendants as part of, and in furtherance of, their and their co-conspirators' contract, combination, or conspiracy were authorized, ordered, or done by their officers, agents, employees, or representatives while actively engaged in the management of their affairs.

249. During the Class Period, Defendants and their co-conspirators entered into a continuing agreement, understanding and conspiracy in restraint of trade to artificially fix, raise, stabilize, and control prices for Fuel Injection Systems, thereby creating anticompetitive effects.

**REDACTED**

250. The anticompetitive acts were intentionally directed at the United States market for Fuel Injection Systems and had a substantial and foreseeable effect on interstate commerce by raising and fixing prices for Fuel Injection Systems throughout the United States.

251. The conspiratorial acts and combinations have caused unreasonable restraints in the market for Fuel Injection Systems

252. As a result of the Defendants' unlawful conduct, Plaintiffs and other similarly situated indirect purchasers in the Nationwide Class who purchased Fuel Injection Systems have been harmed by being forced to pay inflated, supra-competitive prices for Fuel Injection Systems.

253. In formulating and carrying out the alleged agreement, understanding and conspiracy, Defendants and their co-conspirators did those things that they combined and conspired to do, including but not limited to the acts, practices and course of conduct set forth herein.

254. Defendants conspiracy had the following effects, among others:

- (a) Price competition in the market for Fuel Injection Systems has been restrained, suppressed, and/or eliminated in the United States;
- (b) Prices for Fuel Injection Systems sold by Defendants and their co-conspirators have been fixed, raised, maintained, and stabilized at artificially high, non-competitive levels throughout the United States; and
- (c) Plaintiffs and members of the Nationwide Class who purchased Fuel Injection Systems indirectly from Defendants and their co-conspirators have been deprived of the benefits of free and open competition.

**REDACTED**

255. Plaintiffs and members of the Nationwide Class have been injured and will continue to be injured in their business and property by paying more for Fuel Injection Systems purchased indirectly from the Defendants and their co-conspirators than they would have paid and will pay in the absence of the conspiracy.

256. The alleged contract, combination, or conspiracy is a *per se* violation of the federal antitrust laws.

257. Plaintiffs and members of the Nationwide Class are entitled to an injunction against the Defendants, preventing and restraining the violations alleged herein.

**SECOND CLAIM FOR RELIEF**  
**Violation of State Antitrust Statutes**  
**(on behalf of Plaintiffs and the Damages Class)**

258. Plaintiffs incorporate by reference the allegations in the preceding paragraphs.

259. During the Class Period, Defendants and their co-conspirators engaged in a continuing contract, combination or conspiracy with respect to the sale of Fuel Injection Systems in unreasonable restraint of trade and commerce and in violation of the various state antitrust and other statutes set forth below.

260. The contract, combination, or conspiracy consisted of an agreement among the Defendants and their co-conspirators to fix, raise, inflate, stabilize, and/or maintain at artificially supra-competitive prices for Fuel Injection Systems and to allocate customers for Fuel Injection Systems in the United States.

261. In formulating and effectuating this conspiracy, the Defendants and their co-conspirators performed acts in furtherance of the combination and conspiracy, including:

- (a) participating in meetings and conversations among themselves in the United States and elsewhere during which they agreed to price Fuel Injection Systems at certain levels, and otherwise to fix, increase, inflate, maintain, or stabilize effective



**REDACTED**

prices paid by Plaintiffs and members of the Damages Class with respect to Fuel Injection Systems sold in the United States;

(b) allocating customers and markets for Fuel Injection Systems in the United States in furtherance of their agreements; and

(c) participating in meetings and conversations among themselves in the United States and elsewhere to implement, adhere to, and police the unlawful agreements they reached.

262. Defendants and their co-conspirators engaged in the actions described above for the purpose of carrying out their unlawful agreements to fix, maintain, increase, or stabilize prices and to allocate customers with respect to Fuel Injection Systems.

263. Defendants' anticompetitive acts described above were knowing and willful and constitute violations or flagrant violations of the following state antitrust statutes.

264. The Defendants have entered into an unlawful agreement in restraint of trade in violation of the Arizona Revised Statutes, §§ 44-1401, *et seq.*

(a) Defendants' combinations or conspiracies had the following effects: (1) Fuel Injection System price competition was restrained, suppressed, and eliminated throughout Arizona; (2) Fuel Injection System prices were raised, fixed, maintained and stabilized at artificially high levels throughout Arizona; (3) Plaintiffs and members of the Damages Class were deprived of free and open competition; and (4) Plaintiffs and members of the Damages Class paid supra-competitive, artificially inflated prices for Fuel Injection Systems.

(b) During the Class Period, Defendants' illegal conduct substantially affected Arizona commerce.

**REDACTED**

(c) As a direct and proximate result of Defendants' unlawful conduct, Plaintiffs and members of the Damages Class have been injured in their business and property and are threatened with further injury.

(d) By reason of the foregoing, Defendants entered into agreements in restraint of trade in violation of Ariz. Rev. Stat. §§ 44-1401, *et seq.* Accordingly, Plaintiffs and members of the Damages Class seek all forms of relief available under Ariz. Rev. Stat. §§ 44-1401, *et seq.*

265. Defendants have entered into an unlawful agreement in restraint of trade in violation of the California Business and Professions Code, §§ 16700, *et seq.*

(a) During the Class Period, Defendants and their co-conspirators entered into and engaged in a continuing unlawful trust in restraint of the trade and commerce described above in violation of Section 16720, California Business and Professions Code. Defendants, each of them, have acted in violation of Section 16720 to fix, raise, stabilize, and maintain prices of, and allocate markets for, Fuel Injection Systems at supra-competitive levels.

(b) The aforesaid violations of Section 16720, California Business and Professions Code, consisted, without limitation, of a continuing unlawful trust and concert of action among the Defendants and their co-conspirators, the substantial terms of which were to fix, raise, maintain, and stabilize the prices of, and to allocate markets for, Fuel Injection Systems.

(c) For the purpose of forming and effectuating the unlawful trust, the Defendants and their co-conspirators have done those things which they combined and conspired to do, including but not limited to the acts, practices and course of

**REDACTED**

conduct set forth above and the following: (1) Fixing, raising, stabilizing, and pegging the price of Fuel Injection Systems; and (2) Allocating among themselves the production of Fuel Injection Systems.

(d) The combination and conspiracy alleged herein has had, inter alia, the following effects: (1) Price competition in the sale of Fuel Injection Systems has been restrained, suppressed, and/or eliminated in the State of California; (2) Prices for Fuel Injection Systems sold by Defendants and their co-conspirators have been fixed, raised, stabilized, and pegged at artificially high, non-competitive levels in the State of California and throughout the United States; and (3) Those who purchased Fuel Injection Systems directly or indirectly from the Defendants and their co-conspirators have been deprived of the benefit of free and open competition.

(e) As a direct and proximate result of Defendants' unlawful conduct, Plaintiffs and members of the Damages Class have been injured in their business and property in that they paid more for Fuel Injection Systems than they otherwise would have paid in the absence of Defendants' unlawful conduct. As a result of Defendants' violation of Section 16720 of the California Business and Professions Code, Plaintiffs and members of the Damages Class seek treble damages and their cost of suit, including a reasonable attorney's fee, pursuant to Section 16750(a) of the California Business and Professions Code.

266. Defendants have entered into an unlawful agreement in restraint of trade in violation of the District of Columbia Code Annotated §§ 28-4501, *et seq.*

**REDACTED**

(a) Defendants' combinations or conspiracies had the following effects: (1) Fuel Injection Systems price competition was restrained, suppressed, and eliminated throughout the District of Columbia; (2) Fuel Injection System prices were raised, fixed, maintained and stabilized at artificially high levels throughout the District of Columbia; (3) Plaintiffs and members of the Damages Class were deprived of free and open competition; and (4) Plaintiffs and members of the Damages Class paid supra-competitive, artificially inflated prices for Fuel Injection Systems.

(b) During the Class Period, Defendants' illegal conduct substantially affected District of Columbia commerce.

(c) As a direct and proximate result of Defendants' unlawful conduct, Plaintiffs and members of the Damages Class have been injured in their business and property and are threatened with further injury.

(d) By reason of the foregoing, Defendants have entered into agreements in restraint of trade in violation of District of Columbia Code Ann. §§ 28-4501, *et seq.* Accordingly, Plaintiffs and members of the Damages Class seek all forms of relief available under District of Columbia Code Ann. §§ 28-4501, *et seq.*

267. The Defendants have entered into an unlawful agreement in restraint of trade in violation of the Iowa Code §§ 553.1, *et seq.*

(a) Defendants' combinations or conspiracies had the following effects: (1) Fuel Injection Systems price competition was restrained, suppressed, and eliminated throughout Iowa; (2) Fuel Injection Systems prices were raised, fixed, maintained and stabilized at artificially high levels throughout Iowa; (3) Plaintiffs

**REDACTED**

and members of the Damages Class were deprived of free and open competition; and (4) Plaintiffs and members of the Damages Class paid supra-competitive, artificially inflated prices for Fuel Injection Systems.

(b) During the Class Period, Defendants' illegal conduct substantially affected Iowa commerce.

(c) As a direct and proximate result of Defendants' unlawful conduct, Plaintiffs and members of the Damages Class have been injured in their business and property and are threatened with further injury.

(d) By reason of the foregoing, Defendants have entered into agreements in restraint of trade in violation of Iowa Code §§ 553.1, *et seq.* Accordingly, Plaintiffs and members of the Damages Class seek all forms of relief available under Iowa Code §§ 553.1, *et seq.*

268. Defendants have entered into an unlawful agreement in restraint of trade in violation of the Kansas Statutes Annotated, §§ 50-101, *et seq.*

(a) Defendants' combinations or conspiracies had the following effects: (1) Fuel Injection Systems price competition was restrained, suppressed, and eliminated throughout Kansas; (2) Fuel Injection Systems prices were raised, fixed, maintained and stabilized at artificially high levels throughout Kansas; (3) Plaintiffs and members of the Damages Class were deprived of free and open competition; and (4) Plaintiffs and members of the Damages Class paid supra-competitive, artificially inflated prices for Fuel Injection Systems.

(b) During the Class Period, Defendants' illegal conduct substantially affected Kansas commerce.

**REDACTED**

(c) As a direct and proximate result of Defendants' unlawful conduct, Plaintiffs and members of the Damages Class have been injured in their business and property and are threatened with further injury.

(d) By reason of the foregoing, Defendants have entered into agreements in restraint of trade in violation of Kansas Stat. Ann. §§ 50-101, *et seq.*

Accordingly, Plaintiffs and members of the Damages Class seek all forms of relief available under Kansas Stat. Ann. §§ 50-101, *et seq.*

269. Defendants have entered into an unlawful agreement in restraint of trade in violation of the Maine Revised Statutes, Maine Rev. Stat. Ann. 10, §§ 1101, *et seq.*

(a) Defendants' combinations or conspiracies had the following effects: (1) Fuel Injection Systems price competition was restrained, suppressed, and eliminated throughout Maine; (2) Fuel Injection Systems prices were raised, fixed, maintained and stabilized at artificially high levels throughout Maine; (3) Plaintiffs and members of the Damages Class were deprived of free and open competition; and (4) Plaintiffs and members of the Damages Class paid supra-competitive, artificially inflated prices for Fuel Injection Systems.

(b) During the Class Period, Defendants' illegal conduct substantially affected Maine commerce.

(c) As a direct and proximate result of Defendants' unlawful conduct, Plaintiffs and members of the Damages Class have been injured in their business and property and are threatened with further injury.

(d) By reason of the foregoing, Defendants have entered into agreements in restraint of trade in violation of Maine Rev. Stat. Ann. 10, §§ 1101, *et seq.*

**REDACTED**

Accordingly, Plaintiffs and members of the Damages Class seek all relief available under Maine Rev. Stat. Ann. 10, §§ 1101, *et seq.*

270. Defendants have entered into an unlawful agreement in restraint of trade in violation of the Michigan Compiled Laws Annotated §§ 445.771, *et seq.*

(a) Defendants' combinations or conspiracies had the following effects: (1) Fuel Injection Systems price competition was restrained, suppressed, and eliminated throughout Michigan; (2) Fuel Injection Systems prices were raised, fixed, maintained and stabilized at artificially high levels throughout Michigan; (3) Plaintiffs and members of the Damages Class were deprived of free and open competition; and (4) Plaintiffs and members of the Damages Class paid supra-competitive, artificially inflated prices for Fuel Injection Systems.

(b) During the Class Period, Defendants' illegal conduct substantially affected Michigan commerce.

(c) As a direct and proximate result of Defendants' unlawful conduct, Plaintiffs and members of the Damages Class have been injured in their business and property and are threatened with further injury.

(d) By reason of the foregoing, Defendants have entered into agreements in restraint of trade in violation of Michigan Comp. Laws Ann. §§ 445.771, *et seq.* Accordingly, Plaintiffs and members of the Damages Class seek all relief available under Michigan Comp. Laws Ann. §§ 445.771, *et seq.*

271. Defendants have entered into an unlawful agreement in restraint of trade in violation of the Minnesota Annotated Statutes §§ 325D.49, *et seq.*

**REDACTED**

(a) Defendants' combinations or conspiracies had the following effects: (1) Fuel Injection Systems price competition was restrained, suppressed, and eliminated throughout Minnesota; (2) Fuel Injection Systems prices were raised, fixed, maintained and stabilized at artificially high levels throughout Minnesota; (3) Plaintiffs and members of the Damages Class were deprived of free and open competition; and (4) Plaintiffs and members of the Damages Class paid supra-competitive, artificially inflated prices for Fuel Injection Systems.

(b) During the Class Period, the Defendants' illegal conduct substantially affected Minnesota commerce.

(c) As a direct and proximate result of Defendants' unlawful conduct, Plaintiffs and members of the Damages Class have been injured in their business and property and are threatened with further injury.

(d) By reason of the foregoing, Defendants have entered into agreements in restraint of trade in violation of Minnesota Stat. §§ 325D.49, *et seq.* Accordingly, Plaintiffs and members of the Damages Class seek all relief available under Minnesota Stat. §§ 325D.49, *et seq.*

272. Defendants have entered into an unlawful agreement in restraint of trade in violation of the Mississippi Code Annotated §§ 75-21-1, *et seq.*

(a) Defendants' combinations or conspiracies had the following effects: (1) Fuel Injection Systems price competition was restrained, suppressed, and eliminated throughout Mississippi; (2) Fuel Injection Systems prices were raised, fixed, maintained and stabilized at artificially high levels throughout Mississippi; (3) Plaintiffs and members of the Damages Class were deprived of free and open



**REDACTED**

competition; and (4) Plaintiffs and members of the Damages Class paid supra-competitive, artificially inflated prices for Fuel Injection Systems.

(b) During the Class Period, Defendants' illegal conduct substantially affected Mississippi commerce.

(c) As a direct and proximate result of Defendants' unlawful conduct, Plaintiffs and members of the Damages Class have been injured in their business and property and are threatened with further injury.

(d) By reason of the foregoing, Defendants have entered into agreements in restraint of trade in violation of Mississippi Code Ann. §§ 75-21-1, *et seq.*

Accordingly, Plaintiffs and members of the Damages Class seek all relief available under Mississippi Code Ann. §§ 75-21-1, *et seq.*

273. Defendants have entered into an unlawful agreement in restraint of trade in violation of the Nebraska Revised Statutes §§ 59-801, *et seq.*

(a) Defendants' combinations or conspiracies had the following effects: (1) Fuel Injection Systems price competition was restrained, suppressed, and eliminated throughout Nebraska; (2) Fuel Injection Systems prices were raised, fixed, maintained and stabilized at artificially high levels throughout Nebraska; (3) Plaintiffs and members of the Damages Class were deprived of free and open competition; and (4) Plaintiffs and members of the Damages Class paid supra-competitive, artificially inflated prices for Fuel Injection Systems.

(b) During the Class Period, Defendants' illegal conduct substantially affected Nebraska commerce.

**REDACTED**

(c) As a direct and proximate result of Defendants' unlawful conduct, Plaintiffs and members of the Damages Class have been injured in their business and property and are threatened with further injury.

(d) By reason of the foregoing, Defendants have entered into agreements in restraint of trade in violation of Nebraska Revised Statutes §§ 59-801, *et seq.* Accordingly, Plaintiffs and members of the Damages Class seek all relief available under Nebraska Revised Statutes §§ 59-801, *et seq.*

274. Defendants have entered into an unlawful agreement in restraint of trade in violation of the Nevada Revised Statutes Annotated §§ 598A.010, *et seq.*

(a) Defendants' combinations or conspiracies had the following effects: (1) Fuel Injection Systems price competition was restrained, suppressed, and eliminated throughout Nevada; (2) Fuel Injection Systems prices were raised, fixed, maintained and stabilized at artificially high levels throughout Nevada; (3) Plaintiffs and members of the Damages Class were deprived of free and open competition; and (4) Plaintiffs and members of the Damages Class paid supra-competitive, artificially inflated prices for Fuel Injection Systems.

(b) During the Class Period, Defendants' illegal conduct substantially affected Nevada commerce.

(c) As a direct and proximate result of Defendants' unlawful conduct, Plaintiffs and members of the Damages Class have been injured in their business and property and are threatened with further injury.

(d) By reason of the foregoing, Defendants have entered into agreements in restraint of trade in violation of Nevada Rev. Stat. Ann. §§ 598A.010, *et seq.*

**REDACTED**

Accordingly, Plaintiffs and members of the Damages Class seek all relief available under Nevada Rev. Stat. Ann. §§ 598A.010, *et seq.*

275. Defendants have entered into an unlawful agreement in restraint of trade in violation of the New Hampshire Revised Statutes §§ 356:1, *et seq.*

(a) Defendants' combinations or conspiracies had the following effects: (1) Fuel Injection Systems price competition was restrained, suppressed, and eliminated throughout New Hampshire; (2) Fuel Injection Systems prices were raised, fixed, maintained and stabilized at artificially high levels throughout New Hampshire; (3) Plaintiffs and members of the Damages Class were deprived of free and open competition; and (4) Plaintiffs and members of the Damages Class paid supra-competitive, artificially inflated prices for Fuel Injection Systems.

(b) During the Class Period, Defendants' illegal conduct substantially affected New Hampshire commerce.

(c) As a direct and proximate result of Defendants' unlawful conduct, Plaintiffs and members of the Damages Class have been injured in their business and property and are threatened with further injury.

(d) By reason of the foregoing, Defendants have entered into agreements in restraint of trade in violation of New Hampshire Revised Statutes §§ 356:1, *et seq.* Accordingly, Plaintiffs and members of the Damages Class seek all relief available under New Hampshire Revised Statutes §§ 356:1, *et seq.*

276. Defendants have entered into an unlawful agreement in restraint of trade in violation of the New Mexico Statutes Annotated §§ 57-1-1, *et seq.*

**REDACTED**

(a) Defendants' combinations or conspiracies had the following effects: (1) Fuel Injection Systems price competition was restrained, suppressed, and eliminated throughout New Mexico; (2) Fuel Injection Systems prices were raised, fixed, maintained and stabilized at artificially high levels throughout New Mexico; (3) Plaintiffs and members of the Damages Class were deprived of free and open competition; and (4) Plaintiffs and members of the Damages Class paid supra-competitive, artificially inflated prices for Fuel Injection Systems.

(b) During the Class Period, Defendants' illegal conduct substantially affected New Mexico commerce.

(c) As a direct and proximate result of Defendants' unlawful conduct, Plaintiffs and members of the Damages Class have been injured in their business and property and are threatened with further injury.

(d) By reason of the foregoing, Defendants have entered into agreements in restraint of trade in violation of New Mexico Stat. Ann. §§ 57-1-1, *et seq.* Accordingly, Plaintiffs and members of the Damages Class seek all relief available under New Mexico Stat. Ann. §§ 57-1-1, *et seq.*

277. Defendants have entered into an unlawful agreement in restraint of trade in violation of the New York General Business Laws §§ 340, *et seq.*

(a) Defendants' combinations or conspiracies had the following effects: (1) Fuel Injection Systems price competition was restrained, suppressed, and eliminated throughout New York; (2) Fuel Injection Systems prices were raised, fixed, maintained and stabilized at artificially high levels throughout New York; (3) Plaintiffs and members of the Damages Class were deprived of free and open

**REDACTED**

competition; and (4) Plaintiffs and members of the Damages Class paid supra-competitive, artificially inflated prices for Fuel Injection Systems when they purchased vehicles containing Fuel Injection Systems, or purchased products that were otherwise of lower quality than they would have been absent the conspirators illegal acts, or were unable to purchase products that they otherwise would have purchased absent the illegal conduct.

(b) During the Class Period, Defendants' illegal conduct substantially affected New York commerce.

(c) As a direct and proximate result of Defendants' unlawful conduct, Plaintiffs and members of the Damages Class have been injured in their business and property and are threatened with further injury.

(d) By reason of the foregoing, Defendants have entered into agreements in restraint of trade in violation of the New York Donnelly Act, §§ 340, *et seq.* The conduct set forth above is a *per se* violation of the Act. Accordingly, Plaintiffs and members of the Damages Class seek all relief available under New York Gen. Bus. Law §§ 340, *et seq.*

278. Defendants have entered into an unlawful agreement in restraint of trade in violation of the North Carolina General Statutes §§ 75-1, *et seq.*

(a) Defendants' combinations or conspiracies had the following effects: (1) Fuel Injection Systems price competition was restrained, suppressed, and eliminated throughout North Carolina; (2) Fuel Injection Systems prices were raised, fixed, maintained and stabilized at artificially high levels throughout North Carolina; (3) Plaintiffs and members of the Damages Class were deprived of free

**REDACTED**

and open competition; and (4) Plaintiffs and members of the Damages Class paid supra-competitive, artificially inflated prices for Fuel Injection Systems.

(b) During the Class Period, Defendants' illegal conduct substantially affected North Carolina commerce.

(c) As a direct and proximate result of the Defendants' unlawful conduct, Plaintiffs and members of the Damages Class have been injured in their business and property and are threatened with further injury.

(d) By reason of the foregoing, Defendants have entered into agreements in restraint of trade in violation of North Carolina Gen. Stat. §§ 75-1, *et seq.*

Accordingly, Plaintiffs and members of the Damages Class seek all relief available under North Carolina Gen. Stat. §§ 75-1, *et seq.*

279. Defendants have entered into an unlawful agreement in restraint of trade in violation of the North Dakota Century Code §§ 51-08.1-01, *et seq.*

(a) Defendants' combinations or conspiracies had the following effects: (1) Fuel Injection Systems price competition was restrained, suppressed, and eliminated throughout North Dakota; (2) Fuel Injection Systems prices were raised, fixed, maintained and stabilized at artificially high levels throughout North Dakota; (3) Plaintiffs and members of the Damages Class were deprived of free and open competition; and (4) Plaintiffs and members of the Damages Class paid supra-competitive, artificially inflated prices for Fuel Injection Systems.

(b) During the Class Period, Defendants' illegal conduct had a substantial effect on North Dakota commerce.

**REDACTED**

(c) As a direct and proximate result of Defendants' unlawful conduct, Plaintiffs and members of the Damages Class have been injured in their business and property and are threatened with further injury.

(d) By reason of the foregoing, Defendants have entered into agreements in restraint of trade in violation of North Dakota Cent. Code §§ 51-08.1-01, *et seq.* Accordingly, Plaintiffs and members of the Damages Class seek all relief available under North Dakota Cent. Code §§ 51-08.1-01, *et seq.*

280. Defendants have entered into an unlawful agreement in restraint of trade in violation of the Oregon Revised Statutes §§ 646.705, *et seq.*

(a) Defendants' combinations or conspiracies had the following effects: (1) Fuel Injection Systems price competition was restrained, suppressed, and eliminated throughout Oregon; (2) Fuel Injection Systems prices were raised, fixed, maintained and stabilized at artificially high levels throughout Oregon; (3) Plaintiffs and members of the Damages Class were deprived of free and open competition; and (4) Plaintiffs and members of the Damages Class paid supra-competitive, artificially inflated prices for Fuel Injection Systems.

(b) During the Class Period, Defendants' illegal conduct had a substantial effect on Oregon commerce.

(c) As a direct and proximate result of Defendants' unlawful conduct, Plaintiffs and members of the Damages Class have been injured in their business and property and are threatened with further injury.

(d) By reason of the foregoing, Defendants have entered into agreements in restraint of trade in violation of Oregon Revised Statutes §§ 646.705, *et seq.*

**REDACTED**

Accordingly, Plaintiffs and members of the Damages Class seek all relief available under Oregon Revised Statutes §§ 646.705, *et seq.*

281. Defendants have entered into an unlawful agreement in restraint of trade in violation of the South Dakota Codified Laws §§ 37-1-3.1, *et seq.*

(a) Defendants' combinations or conspiracies had the following effects: (1) Fuel Injection Systems price competition was restrained, suppressed, and eliminated throughout South Dakota; (2) Fuel Injection Systems prices were raised, fixed, maintained and stabilized at artificially high levels throughout South Dakota; (3) Plaintiffs and members of the Damages Class were deprived of free and open competition; and (4) Plaintiffs and members of the Damages Class paid supra-competitive, artificially inflated prices for Fuel Injection Systems.

(b) During the Class Period, Defendants' illegal conduct had a substantial effect on South Dakota commerce.

(c) As a direct and proximate result of Defendants' unlawful conduct, Plaintiffs and members of the Damages Class have been injured in their business and property and are threatened with further injury.

(d) By reason of the foregoing, Defendants have entered into agreements in restraint of trade in violation of South Dakota Codified Laws Ann. §§ 37-1, *et seq.* Accordingly, Plaintiffs and members of the Damages Class seek all relief available under South Dakota Codified Laws Ann. §§ 37-1, *et seq.*

282. Defendants have entered into an unlawful agreement in restraint of trade in violation of the Tennessee Code Annotated §§ 47-25-101, *et seq.*



**REDACTED**

(a) Defendants' combinations or conspiracies had the following effects: (1) Fuel Injection Systems price competition was restrained, suppressed, and eliminated throughout Tennessee; (2) Fuel Injection Systems prices were raised, fixed, maintained and stabilized at artificially high levels throughout Tennessee; (3) Plaintiffs and members of the Damages Class were deprived of free and open competition; and (4) Plaintiffs and members of the Damages Class paid supra-competitive, artificially inflated prices for Fuel Injection Systems.

(b) During the Class Period, the Defendants' illegal conduct had a substantial effect on Tennessee commerce.

(c) As a direct and proximate result of the Defendants' unlawful conduct, Plaintiffs and members of the Damages Class have been injured in their business and property and are threatened with further injury.

(d) By reason of the foregoing, Defendants have entered into agreements in restraint of trade in violation of Tennessee Code Ann. §§ 47-25-101, *et seq.* Accordingly, Plaintiffs and members of the Damages Class seek all relief available under Tennessee Code Ann. §§ 47-25-101, *et seq.*

283. Defendants have entered into an unlawful agreement in restraint of trade in violation of the Utah Code Annotated §§ 76-10-911, *et seq.*

(a) Defendants' combinations or conspiracies had the following effects: (1) Fuel Injection Systems price competition was restrained, suppressed, and eliminated throughout Utah; (2) Fuel Injection Systems prices were raised, fixed, maintained and stabilized at artificially high levels throughout Utah; (3) Plaintiffs and members of the Damages Class were deprived of free and open competition;

**REDACTED**

and (4) Plaintiffs and members of the Damages Class paid supra-competitive, artificially inflated prices for Fuel Injection Systems.

(b) During the Class Period, Defendants' illegal conduct had a substantial effect on Utah commerce.

(c) As a direct and proximate result of Defendants' unlawful conduct, Plaintiffs and members of the Damages Class have been injured in their business and property and are threatened with further injury.

(d) By reason of the foregoing, Defendants have entered into agreements in restraint of trade in violation of Utah Code Annotated §§ 76-10-911, *et seq.*

Accordingly, Plaintiffs and members of the Damages Class seek all relief available under Utah Code Annotated §§ 76-10-911, *et seq.*

284. Defendants have entered into an unlawful agreement in restraint of trade in violation of the Vermont Stat. Ann. 9 §§ 2453, *et seq.*

(a) Defendants' combinations or conspiracies had the following effects: (1) Fuel Injection Systems price competition was restrained, suppressed, and eliminated throughout Vermont; (2) Fuel Injection Systems prices were raised, fixed, maintained and stabilized at artificially high levels throughout Vermont; (3) Plaintiffs and members of the Damages Class were deprived of free and open competition; and (4) Plaintiffs and members of the Damages Class paid supra-competitive, artificially inflated prices for Fuel Injection Systems.

(b) During the Class Period, Defendants' illegal conduct had a substantial effect on Vermont commerce.

**REDACTED**

(c) As a direct and proximate result of Defendants' unlawful conduct, Plaintiffs and members of the Damages Class have been injured in their business and property and are threatened with further injury.

(d) By reason of the foregoing, Defendants have entered into agreements in restraint of trade in violation of Vermont Stat. Ann. 9 §§ 2453, *et seq.*

Accordingly, Plaintiffs and members of the Damages Class seek all relief available under Vermont Stat. Ann. 9 §§ 2453, *et seq.*

285. Defendants have entered into an unlawful agreement in restraint of trade in violation of the West Virginia Code §§ 47-18-1, *et seq.*

(a) Defendants' combinations or conspiracies had the following effects: (1) Fuel Injection Systems price competition was restrained, suppressed, and eliminated throughout West Virginia; (2) Fuel Injection Systems prices were raised, fixed, maintained and stabilized at artificially high levels throughout West Virginia; (3) Plaintiffs and members of the Damages Class were deprived of free and open competition; and (4) Plaintiffs and members of the Damages Class paid supra-competitive, artificially inflated prices for Fuel Injection Systems.

(b) During the Class Period, Defendants' illegal conduct had a substantial effect on West Virginia commerce.

(c) As a direct and proximate result of Defendants' unlawful conduct, Plaintiffs and members of the Damages Class have been injured in their business and property and are threatened with further injury.

(d) By reason of the foregoing, Defendants have entered into agreements in restraint of trade in violation of West Virginia Code §§ 47-18-1, *et seq.*

**REDACTED**

Accordingly, Plaintiffs and members of the Damages Class seek all relief available under West Virginia Code §§ 47-18-1, *et seq.*

286. Defendants have entered into an unlawful agreement in restraint of trade in violation of the Wisconsin Statutes §§ 133.01, *et seq.*

(a) Defendants' combinations or conspiracies had the following effects: (1) Fuel Injection Systems price competition was restrained, suppressed, and eliminated throughout Wisconsin; (2) Fuel Injection Systems prices were raised, fixed, maintained and stabilized at artificially high levels throughout Wisconsin; (3) Plaintiffs and members of the Damages Class were deprived of free and open competition; and (4) Plaintiffs and members of the Damages Class paid supra-competitive, artificially inflated prices for Fuel Injection Systems.

(b) During the Class Period, Defendants' illegal conduct had a substantial effect on Wisconsin commerce.

(c) As a direct and proximate result of Defendants' unlawful conduct, Plaintiffs and members of the Damages Class have been injured in their business and property and are threatened with further injury.

(d) By reason of the foregoing, Defendants have entered into agreements in restraint of trade in violation of Wisconsin Stat. §§ 133.01, *et seq.* Accordingly, Plaintiffs and members of the Damages Class seek all relief available under Wisconsin Stat. §§ 133.01, *et seq.*

287. Plaintiffs and members of the Damages Class in each of the above states have been injured in their business and property by reason of Defendants' unlawful combination, contract, conspiracy and agreement. Plaintiffs and members of the Damages Class have paid

**REDACTED**

more for Fuel Injection Systems than they otherwise would have paid in the absence of Defendants' unlawful conduct. This injury is of the type the antitrust laws of the above states were designed to prevent and flows from that which makes Defendants' conduct unlawful.

288. In addition, Defendants have profited significantly from the aforesaid conspiracy. Defendants' profits derived from their anticompetitive conduct come at the expense and detriment of the Plaintiffs and the members of the Damages Class.

289. Accordingly, Plaintiffs and the members of the Damages Class in each of the above jurisdictions seek damages (including statutory damages where applicable), to be trebled or otherwise increased as permitted by a particular jurisdiction's antitrust law, and costs of suit, including reasonable attorneys' fees, to the extent permitted by the above state laws.

**THIRD CLAIM FOR RELIEF**  
**Violation of State Consumer Protection Statutes**  
**(on behalf of Plaintiffs and the Damages Class)**

290. Plaintiffs incorporate and reallege, as though fully set forth herein, each and every allegation set forth in the preceding paragraphs of this Complaint.

291. Defendants engaged in unfair competition or unfair, unconscionable, deceptive or fraudulent acts or practices in violation of the state consumer protection and unfair competition statutes listed below.

292. Defendants have knowingly entered into an unlawful agreement in restraint of trade in violation of the Arkansas Code Annotated, § 4-88-101, *et seq.*

(a) Defendants knowingly agreed to, and did in fact, act in restraint of trade or commerce by affecting, fixing, controlling, and/or maintaining at non-competitive and artificially inflated levels, the prices at which Fuel Injection Systems were sold, distributed, or obtained in Arkansas and took efforts to conceal their agreements from Plaintiffs and members of the Damages Class.

**REDACTED**

(b) The aforementioned conduct on the part of the Defendants constituted “unconscionable” and “deceptive” acts or practices in violation of Arkansas Code Annotated, § 4-88-107(a)(10).

(c) Defendants’ unlawful conduct had the following effects: (1) Fuel Injection System price competition was restrained, suppressed, and eliminated throughout Arkansas; (2) Fuel Injection System prices were raised, fixed, maintained, and stabilized at artificially high levels throughout Arkansas; (3) Plaintiffs and the members of the Damages Class were deprived of free and open competition; and (4) Plaintiffs and the members of the Damages Class paid supra-competitive, artificially inflated prices for Fuel Injection System.

(d) During the Class Period, Defendants’ illegal conduct substantially affected Arkansas commerce and consumers.

(e) As a direct and proximate result of the unlawful conduct of the Defendants, Plaintiff and the members of the Damages Class have been injured in their business and property and are threatened with further injury.

(f) Defendants have engaged in unfair competition or unfair or deceptive acts or practices in violation of Arkansas Code Annotated, § 4-88-107(a)(10) and, accordingly, Plaintiffs and the members of the Damages Class seek all relief available under that statute.

293. Defendants have engaged in unfair competition or unfair, unconscionable, deceptive or fraudulent acts or practices in violation of California Business and Professions Code § 17200, *et seq.*

**REDACTED**

(a) During the Class Period, Defendants marketed, sold, or distributed Fuel Injector Systems in California, and committed and continue to commit acts of unfair competition, as defined by Sections 17200, *et seq.* of the California Business and Professions Code, by engaging in the acts and practices specified above.

(b) This claim is instituted pursuant to Sections 17203 and 17204 of the California Business and Professions Code, to obtain restitution from these Defendants for acts, as alleged herein, that violated Section 17200 of the California Business and Professions Code, commonly known as the Unfair Competition Law.

(c) Defendants' conduct as alleged herein violated Section 17200. The acts, omissions, misrepresentations, practices and non-disclosures of Defendants, as alleged herein, constituted a common, continuous, and continuing course of conduct of unfair competition by means of unfair, unlawful, and/or fraudulent business acts or practices within the meaning of California Business and Professions Code, Section 17200, *et seq.*, including, but not limited to, the following: (1) the violations of Section 1 of the Sherman Act, as set forth above; (2) the violations of Section 16720, *et seq.*, of the California Business and Professions Code, set forth above;

(d) Defendants' acts, omissions, misrepresentations, practices, and non-disclosures, as described above, whether or not in violation of Section 16720, *et seq.*, of the California Business and Professions Code, and whether or not

**REDACTED**

concerted or independent acts, are otherwise unfair, unconscionable, unlawful or fraudulent;

(e) Defendants' acts or practices are unfair to consumers of Fuel Injection Systems (or vehicles containing them) in the State of California within the meaning of Section 17200, California Business and Professions Code;

(f) Defendants' acts and practices are fraudulent or deceptive within the meaning of Section 17200 of the California Business and Professions Code.

(g) Plaintiffs and members of the Damages Class are entitled to full restitution and/or disgorgement of all revenues, earnings, profits, compensation, and benefits that may have been obtained by Defendants as a result of such business acts or practices.

(h) The illegal conduct alleged herein is continuing and there is no indication that Defendants will not continue such activity into the future.

(i) The unlawful and unfair business practices of Defendants, each of them, have caused and continue to cause Plaintiffs and the members of the Damages Class to pay supra-competitive and artificially-inflated prices for Fuel Injection Systems (or vehicles containing them). Plaintiffs and the members of the Damages Class suffered injury in fact and lost money or property as a result of such unfair competition.

(j) The conduct of Defendants as alleged in this Complaint violates Section 17200 of the California Business and Professions Code.

(k) As alleged in this Complaint, Defendants and their co-conspirators have been unjustly enriched as a result of their wrongful conduct and by Defendants'



**REDACTED**

unfair competition. Plaintiffs and the members of the Damages Class are accordingly entitled to equitable relief including restitution and/or disgorgement of all revenues, earnings, profits, compensation, and benefits that may have been obtained by Defendants as a result of such business practices, pursuant to the California Business and Professions Code, Sections 17203 and 17204.

294. Defendants have engaged in unfair competition or unfair, unconscionable, or deceptive acts or practices in violation of District of Columbia Code § 28-3901, *et seq.*

(a) Defendants agreed to, and did in fact, act in restraint of trade or commerce by affecting, fixing, controlling and/or maintaining, at artificial and/or non-competitive levels, the prices at which Fuel Injection Systems were sold, distributed or obtained in the District of Columbia.

(b) The foregoing conduct constitutes “unlawful trade practices,” within the meaning of D.C. Code § 28-3904. Plaintiffs were not aware of Defendants’ price-fixing conspiracy and were therefore unaware that they were being unfairly and illegally overcharged. There was a gross disparity of bargaining power between the parties with respect to the price charged by Defendants for Fuel Injection Systems. Defendants had the sole power to set that price and Plaintiffs had no power to negotiate a lower price. Moreover, Plaintiffs lacked any meaningful choice in purchasing Fuel Injection Systems because they were unaware of the unlawful overcharge and there was no alternative source of supply through which Plaintiffs could avoid the overcharges. Defendants’ conduct with regard to sales of Fuel Injection Systems, including their illegal conspiracy to secretly fix the price of Fuel Injection Systems at supra-competitive levels and overcharge

**REDACTED**

consumers, was substantively unconscionable because it was one-sided and unfairly benefited Defendants at the expense of Plaintiffs and the public.

Defendants took grossly unfair advantage of Plaintiffs. The suppression of competition that has resulted from Defendants' conspiracy has ultimately resulted in unconscionably higher prices for consumers so that there was a gross disparity between the price paid and the value received for Fuel Injection Systems.

(c) Defendants' unlawful conduct had the following effects: (1) Fuel Injection Systems price competition was restrained, suppressed, and eliminated throughout the District of Columbia; (2) Fuel Injection Systems prices were raised, fixed, maintained, and stabilized at artificially high levels throughout the District of Columbia; (3) Plaintiffs and the Damages Class were deprived of free and open competition; and (4) Plaintiffs and the Damages Class paid supra-competitive, artificially inflated prices for Fuel Injection Systems.

(d) As a direct and proximate result of Defendants' conduct, Plaintiffs and members of the Damages Class have been injured and are threatened with further injury. Defendants have engaged in unfair competition or unfair or deceptive acts or practices in violation of District of Columbia Code § 28-3901, *et seq.*, and, accordingly, Plaintiffs and members of the Damages Class seek all relief available under that statute.

295. Defendants have engaged in unfair competition or unfair, unconscionable, or deceptive acts or practices in violation of the Florida Deceptive and Unfair Trade Practices Act, Fla. Stat. §§ 501.201, *et seq.*

**REDACTED**

(a) Defendants' unlawful conduct had the following effects: (1) Fuel Injection Systems price competition was restrained, suppressed, and eliminated throughout Florida; (2) Fuel Injection Systems prices were raised, fixed, maintained, and stabilized at artificially high levels throughout Florida; (3) Plaintiffs and members of the Damages Class were deprived of free and open competition; and (4) Plaintiffs and members of the Damages Class paid supra-competitive, artificially inflated prices for Fuel Injection Systems.

(b) During the Class Period, Defendants' illegal conduct substantially affected Florida commerce and consumers.

(c) As a direct and proximate result of Defendants' unlawful conduct, Plaintiffs and members of the Damages Class have been injured and are threatened with further injury.

(d) Defendants have engaged in unfair competition or unfair or deceptive acts or practices in violation of Florida Stat. § 501.201, *et seq.*, and, accordingly, Plaintiffs and members of the Damages Class seek all relief available under that statute.

296. Defendants have engaged in unfair competition or unfair, unconscionable, or deceptive acts or practices in violation of the Hawaii Revised Statutes Annotated §§ 480-1, *et seq.*

(a) Defendants' unlawful conduct had the following effects: (1) Fuel Injection Systems price competition was restrained, suppressed, and eliminated throughout Hawaii; (2) Fuel Injection Systems prices were raised, fixed, maintained, and stabilized at artificially high levels throughout Hawaii; (3)

**REDACTED**

Plaintiffs and members of the Damages Class were deprived of free and open competition; and (4) Plaintiffs and members of the Damages Class paid supra-competitive, artificially inflated prices for Fuel Injection Systems.

(b) During the Class Period, the Defendants' illegal conduct substantially affected Hawaii commerce and consumers.

(c) As a direct and proximate result of Defendants' unlawful conduct, Plaintiffs and members of the Damages Class have been injured and are threatened with further injury.

(d) Defendants have engaged in unfair competition or unfair or deceptive acts or practices in violation of Hawaii Rev. Stat. § 480, *et seq.*, and, accordingly, Plaintiffs and members of the Damages Class seek all relief available under that statute.

297. Defendants have engaged in unfair competition or unfair, unconscionable, or deceptive acts or practices in violation of Mass. G.L. c. 93A, §2.

(a) Defendants were engaged in trade or commerce as defined by G.L. c. 93A.

(b) Defendants agreed to, and did in fact, act in restraint of trade or commerce in a market which includes Massachusetts, by affecting, fixing, controlling and/or maintaining at artificial and non-competitive levels, the prices at which Fuel Injection Systems were sold, distributed, or obtained in Massachusetts and took efforts to conceal their agreements from Plaintiffs and members of the Damages Class.

**REDACTED**

(c) Defendants' unlawful conduct had the following effects: (1) Fuel Injection Systems price competition was restrained, suppressed, and eliminated throughout Massachusetts; (2) Fuel Injection Systems prices were raised, fixed, maintained, and stabilized at artificially high levels throughout Massachusetts; (3) Plaintiffs and members of the Damages Class were deprived of free and open competition; and (4) Plaintiffs and members of the Damages Class paid supra-competitive, artificially inflated prices for Fuel Injection Systems.

(d) As a direct and proximate result of Defendants' unlawful conduct, Plaintiffs and members of the Damages Class were injured and are threatened with further injury.

(e) Certain of the Defendants have or will be served with a demand letter in accordance with G.L. c. 93A, § 9, or, upon information and belief, such service of a demand letter was unnecessary due to the defendant not maintaining a place of business within the Commonwealth of Massachusetts or not keeping assets within the Commonwealth. More than thirty days has passed since such demand letters were served, and each Defendant served has failed to make a reasonable settlement offer.

(f) By reason of the foregoing, Defendants engaged in unfair competition and unfair or deceptive acts or practices, in violation of G.L. c. 93A, §2. Defendants' and their co-conspirators' violations of Chapter 93A were knowing or willful, entitling Plaintiffs and members of the Damages Class to multiple damages.

**REDACTED**

298. Defendants have engaged in unfair competition or unfair, unconscionable, or deceptive acts or practices in violation of the Missouri Merchandising Practices Act, Mo. Rev. Stat. § 407.010, *et. seq.*

- (a) Plaintiffs and members of this Damages Class purchased Fuel Injection Systems for personal, family, or household purposes.
- (b) Defendants engaged in the conduct described herein in connection with the sale of Fuel Injection Systems in trade or commerce in a market that includes Missouri.
- (c) Defendants agreed to, and did in fact affect, fix, control, and/or maintain, at artificial and non-competitive levels, the prices at which Fuel Injection Systems were sold, distributed, or obtained in Missouri, which conduct constituted unfair practices in that it was unlawful under federal and state law, violated public policy, was unethical, oppressive and unscrupulous, and caused substantial injury to Plaintiffs and members of the Damages Class.
- (d) Defendants concealed, suppressed, and omitted to disclose material facts to Plaintiffs and members of the Damages Class concerning Defendants' unlawful activities and artificially inflated prices for Fuel Injection Systems. The concealed, suppressed, and omitted facts would have been important to Plaintiffs and members of the Damages Class as they related to the cost of Fuel Injection Systems they purchased.
- (e) Defendants misrepresented the real cause of price increases and/or the absence of price reductions in Fuel Injection Systems by making public statements that were not in accord with the facts.

**REDACTED**

(f) Defendants' statements and conduct concerning the price of Fuel Injection Systems were deceptive as they had the tendency or capacity to mislead Plaintiffs and members of the Damages Class to believe that they were purchasing Fuel Injection Systems at prices established by a free and fair market.

(g) Defendants' unlawful conduct had the following effects: (1) Fuel Injection Systems price competition was restrained, suppressed, and eliminated throughout Missouri; (2) Fuel Injection Systems prices were raised, fixed, maintained, and stabilized at artificially high levels throughout Missouri; (3) Plaintiffs and members of the Damages Class were deprived of free and open competition; and (4) Plaintiffs and members of the Damages Class paid supra-competitive, artificially inflated prices for Fuel Injection Systems.

(h) The foregoing acts and practices constituted unlawful practices in violation of the Missouri Merchandising Practices Act.

(i) As a direct and proximate result of the above-described unlawful practices, Plaintiffs and members of the Damages Class suffered ascertainable loss of money or property.

(j) Accordingly, Plaintiffs and members of the Damages Class seek all relief available under Missouri's Merchandising Practices Act, specifically Mo. Rev. Stat. § 407.020, which prohibits "the act, use or employment by any person of any deception, fraud, false pretense, false promise, misrepresentation, unfair practice or the concealment, suppression, or omission of any material fact in connection with the sale or advertisement of any merchandise in trade or commerce..." as further interpreted by the Missouri Code of State Regulations, 15 CSR 60-7.010,

**REDACTED**

*et seq.*, 15 CSR 60-8.010, *et seq.*, and 15 CSR 60-9.010, *et seq.*, and Mo. Rev. Stat. § 407.025, which provides for the relief sought in this count.

299. Defendants have engaged in unfair competition or unfair, unconscionable, or deceptive acts or practices in violation of the Montana Consumer Protection Act of 1973, Mont. Code, §§ 30-14-101, *et seq.*

(a) Defendants' unlawful conduct had the following effects: (1) Fuel Injection Systems price competition was restrained, suppressed, and eliminated throughout Montana; (2) Fuel Injection Systems prices were raised, fixed, maintained, and stabilized at artificially high levels throughout Montana; (3) Plaintiffs and members of the Damages Class were deprived of free and open competition; and (4) Plaintiffs and members of the Damages Class paid supra-competitive, artificially inflated prices for Fuel Injection Systems.

(b) During the Class Period, Defendants' illegal conduct substantially affected Montana commerce and consumers.

(c) As a direct and proximate result of Defendants' unlawful conduct, Plaintiffs and members of the Damages Class have been injured and are threatened with further injury.

(d) Defendants have engaged in unfair competition or unfair or deceptive acts or practices in violation of Mont. Code, §§ 30-14-101, *et seq.*, and, accordingly, Plaintiffs and members of the Damages Class seek all relief available under that statute.

300. Defendants have engaged in unfair competition or unfair, unconscionable, or deceptive acts or practices in violation of the New Mexico Stat. § 57-12-1, *et seq.*



**REDACTED**

(a) Defendants agreed to, and did in fact, act in restraint of trade or commerce by affecting, fixing, controlling and/or maintaining at non-competitive and artificially inflated levels, the prices at which Fuel Injection Systems were sold, distributed or obtained in New Mexico and took efforts to conceal their agreements from Plaintiffs and members of the Damages Class.

(b) The aforementioned conduct on the part of Defendants constituted “unconscionable trade practices,” in violation of N.M.S.A. Stat. § 57-12-3, in that such conduct, inter alia, resulted in a gross disparity between the value received by Plaintiffs and the members of the Damages Class and the prices paid by them for Fuel Injection Systems as set forth in N.M.S.A., § 57-12-2E. Plaintiffs were not aware of Defendants’ price-fixing conspiracy and were therefore unaware that they were being unfairly and illegally overcharged. There was a gross disparity of bargaining power between the parties with respect to the price charged by Defendants for Fuel Injection Systems. Defendants had the sole power to set that price and Plaintiffs had no power to negotiate a lower price. Moreover, Plaintiffs lacked any meaningful choice in purchasing Fuel Injection Systems because they were unaware of the unlawful overcharge and there was no alternative source of supply through which Plaintiffs’ could avoid the overcharges. Defendants’ conduct with regard to sales of Fuel Injection Systems, including their illegal conspiracy to secretly fix the price of Fuel Injection Systems at supra-competitive levels and overcharge consumers, was substantively unconscionable because it was one-sided and unfairly benefited Defendants at the expense of Plaintiffs and the public. Defendants took grossly unfair advantage of Plaintiffs. The

**REDACTED**

suppression of competition that has resulted from Defendants' conspiracy has ultimately resulted in unconscionably higher prices for consumers so that there was a gross disparity between the price paid and the value received for Fuel Injection Systems.

(c) Defendants' unlawful conduct had the following effects: (1) Fuel Injection Systems price competition was restrained, suppressed, and eliminated throughout New Mexico; (2) Fuel Injection Systems prices were raised, fixed, maintained, and stabilized at artificially high levels throughout New Mexico; (3) Plaintiffs and the members of the Damages Class were deprived of free and open competition; and (4) Plaintiffs and the members of the Damages Class paid supra-competitive, artificially inflated prices for Fuel Injection Systems.

(d) During the Class Period, Defendants' illegal conduct substantially affected New Mexico commerce and consumers.

(e) As a direct and proximate result of the unlawful conduct of Defendants, Plaintiffs and the members of the Damages Class have been injured and are threatened with further injury.

(f) Defendants have engaged in unfair competition or unfair or deceptive acts or practices in violation of New Mexico Stat. § 57-12-1, *et seq.*, and, accordingly, Plaintiffs and the members of the Damages Class seek all relief available under that statute.

301. Defendants have engaged in unfair competition or unfair, unconscionable, or deceptive acts or practices in violation of N.Y. Gen. Bus. Law § 349, *et seq.*

**REDACTED**

(a) Defendants agreed to, and did in fact, act in restraint of trade or commerce by affecting, fixing, controlling and/or maintaining, at artificial and non-competitive levels, the prices at which Fuel Injection Systems were sold, distributed or obtained in New York and took efforts to conceal their agreements from Plaintiffs and members of the Damages Class.

(b) Defendants and their co-conspirators made public statements about the prices of Fuel Injection Systems and products containing Fuel Injection Systems that Defendants knew would be seen by New York consumers; such statements either omitted material information that rendered the statements that they made materially misleading or affirmatively misrepresented the real cause of price increases for Fuel Injection Systems and products containing Fuel Injection Systems; and Defendants alone possessed material information that was relevant to consumers, but failed to provide the information.

(c) Because of Defendants' unlawful trade practices in the State of New York, New York consumer class members who indirectly purchased Fuel Injection Systems were misled to believe that they were paying a fair price for Fuel Injection Systems or the price increases for Fuel Injection Systems were for valid business reasons; and similarly situated consumers were potentially affected by Defendants' conspiracy.

(d) Defendants knew that their unlawful trade practices with respect to pricing Fuel Injection Systems would have an impact on New York consumers and not just the Defendants' direct customers.

**REDACTED**

(e) Defendants knew that their unlawful trade practices with respect to pricing Fuel Injection Systems would have a broad impact, causing consumer class members who indirectly purchased Fuel Injection Systems to be injured by paying more for Fuel Injection Systems than they would have paid in the absence of Defendants' unlawful trade acts and practices.

(f) The conduct of the Defendants described herein constitutes consumer-oriented deceptive acts or practices within the meaning of N.Y. Gen. Bus. Law § 349, which resulted in consumer injury and broad adverse impact on the public at large, and harmed the public interest of New York State in an honest marketplace in which economic activity is conducted in a competitive manner.

(g) Defendants' unlawful conduct had the following effects: (1) Fuel Injection Systems price competition was restrained, suppressed, and eliminated throughout New York; (2) Fuel Injection Systems prices were raised, fixed, maintained, and stabilized at artificially high levels throughout New York; (3) Plaintiffs and members of the Damages Class were deprived of free and open competition; and (4) Plaintiffs and members of the Damages Class paid supra-competitive, artificially inflated prices for Fuel Injection Systems.

(h) During the Class Period, Defendants' marketed, sold, or distributed Fuel Injection Systems in New York, and Defendants' illegal conduct substantially affected New York commerce and consumers.

(i) During the Class Period, each of the Defendants named herein, directly, or indirectly and through affiliates they dominated and controlled, manufactured, sold and/or distributed Fuel Injection Systems in New York.

**REDACTED**

(j) Plaintiffs and members of the Damages Class seek all relief available pursuant to N.Y. Gen. Bus. Law § 349 (h).

302. Defendants have engaged in unfair competition or unfair, unconscionable, or deceptive acts or practices in violation of North Carolina Gen. Stat. § 75-1.1, *et seq.*

(a) Defendants agreed to, and did in fact, act in restraint of trade or commerce by affecting, fixing, controlling and/or maintaining, at artificial and non-competitive levels, the prices at which Fuel Injection Systems were sold, distributed or obtained in North Carolina and took efforts to conceal their agreements from Plaintiffs and members of the Damages Class.

(b) Defendants' price-fixing conspiracy could not have succeeded absent deceptive conduct by Defendants to cover up their illegal acts. Secrecy was integral to the formation, implementation and maintenance of Defendants' price-fixing conspiracy. Defendants committed inherently deceptive and self-concealing actions, of which Plaintiffs could not possibly have been aware. Defendants and their co-conspirators publicly provided pre-textual and false justifications regarding their price increases. Defendants' public statements concerning the price of Fuel Injection Systems created the illusion of competitive pricing controlled by market forces rather than supra-competitive pricing driven by Defendants' illegal conspiracy. Moreover, Defendants deceptively concealed their unlawful activities by mutually agreeing not to divulge the existence of the conspiracy to outsiders, conducting meetings and conversations in secret, confining the plan to a small group of higher-level officials at each company and avoiding the creation of documents which would reveal the antitrust violations.

**REDACTED**

(c) The conduct of the Defendants described herein constitutes consumer-oriented deceptive acts or practices within the meaning of North Carolina law, which resulted in consumer injury and broad adverse impact on the public at large, and harmed the public interest of North Carolina consumers in an honest marketplace in which economic activity is conducted in a competitive manner.

(d) Defendants' unlawful conduct had the following effects: (1) Fuel Injection Systems price competition was restrained, suppressed, and eliminated throughout North Carolina; (2) Fuel Injection Systems prices were raised, fixed, maintained, and stabilized at artificially high levels throughout North Carolina; (3) Plaintiffs and members of the Damages Class were deprived of free and open competition; and (4) Plaintiffs and members of the Damages Class paid supra-competitive, artificially inflated prices for Fuel Injection Systems.

(e) During the Class Period, Defendants' marketed, sold, or distributed Fuel Injection Systems in North Carolina, and Defendants' illegal conduct substantially affected North Carolina commerce and consumers.

(f) During the Class Period, each of the Defendants named herein, directly, or indirectly and through affiliates they dominated and controlled, manufactured, sold and/or distributed Fuel Injection Systems in North Carolina.

(g) Plaintiffs and members of the Damages Class seek actual damages for their injuries caused by these violations in an amount to be determined at trial and are threatened with further injury. Defendants have engaged in unfair competition or unfair or deceptive acts or practices in violation of North Carolina Gen. Stat. §

**REDACTED**

75-1.1, *et seq.*, and, accordingly, Plaintiffs and members of the Damages Class seek all relief available under that statute.

303. Defendants have engaged in unfair competition or unfair, unconscionable, or deceptive acts or practices in violation of the Rhode Island Unfair Trade Practice and Consumer Protection Act, R.I. Gen. Laws §§ 6-13.1-1, *et seq.*

(a) Members of this Damages Class purchased Fuel Injection Systems for personal, family, or household purposes.

(b) Defendants agreed to, and did in fact, act in restraint of trade or commerce in a market that includes Rhode Island, by affecting, fixing, controlling, and/or maintaining, at artificial and non-competitive levels, the prices at which Fuel Injection Systems were sold, distributed, or obtained in Rhode Island.

(c) Defendants deliberately failed to disclose material facts to Plaintiffs and members of the Damages Class concerning Defendants' unlawful activities and artificially inflated prices for Fuel Injection Systems. Defendants owed a duty to disclose such facts, and considering the relative lack of sophistication of the average, non-business consumer, Defendants breached that duty by their silence.

Defendants misrepresented to all consumers during the Class Period that Defendants' Fuel Injection System prices were competitive and fair.

(d) Defendants' unlawful conduct had the following effects: (1) Fuel Injection Systems price competition was restrained, suppressed, and eliminated throughout Rhode Island; (2) Fuel Injection Systems prices were raised, fixed, maintained, and stabilized at artificially high levels throughout Rhode Island; (3) Plaintiffs and members of the Damages Class were deprived of free and open

**REDACTED**

competition; and (4) Plaintiffs and members of the Damages Class paid supra-competitive, artificially inflated prices for Fuel Injection Systems.

(e) As a direct and proximate result of the Defendants' violations of law, Plaintiffs and members of the Damages Class suffered an ascertainable loss of money or property as a result of Defendants' use or employment of unconscionable and deceptive commercial practices as set forth above. That loss was caused by Defendants' willful and deceptive conduct, as described herein.

(f) Defendants' deception, including their affirmative misrepresentations and omissions concerning the price of Fuel Injection Systems, likely misled all consumers acting reasonably under the circumstances to believe that they were purchasing Fuel Injection Systems at prices set by a free and fair market. Defendants' affirmative misrepresentations and omissions constitute information important to Plaintiffs and members of the Damages Class as they related to the cost of Fuel Injection Systems they purchased.

(g) Defendants have engaged in unfair competition or unfair or deceptive acts or practices in violation of Rhode Island Gen. Laws. § 6-13.1-1, *et seq.*, and, accordingly, Plaintiffs and members of the Damages Class seek all relief available under that statute.

304. Defendants have engaged in unfair competition or unfair, unconscionable, or deceptive acts or practices in violation of South Carolina Unfair Trade Practices Act, S.C. Code Ann. §§ 39-5-10, *et seq.*

(a) Defendants' combinations or conspiracies had the following effects: (1) Fuel Injection Systems price competition was restrained, suppressed, and



**REDACTED**

eliminated throughout South Carolina; (2) Fuel Injection Systems prices were raised, fixed, maintained, and stabilized at artificially high levels throughout South Carolina; (3) Plaintiffs and members of the Damages Class were deprived of free and open competition; and (4) Plaintiffs and members of the Damages Class paid supra-competitive, artificially inflated prices for Fuel Injection Systems.

(b) During the Class Period, Defendants' illegal conduct had a substantial effect on South Carolina commerce.

(c) As a direct and proximate result of Defendants' unlawful conduct, Plaintiffs and members of the Damages Class have been injured in their business and property and are threatened with further injury.

(d) Defendants have engaged in unfair competition or unfair or deceptive acts or practices in violation of S.C. Code Ann. §§ 39-5-10, *et seq.*, and, accordingly, Plaintiffs and the members of the Damages Class seek all relief available under that statute.

305. Defendants have engaged in unfair competition or unfair, unconscionable, or deceptive acts or practices in violation of 9 Vermont § 2451, *et seq.*

(a) Defendants and their co-conspirators agreed to, and did in fact, act in restraint of trade or commerce in a market that includes Vermont by affecting, fixing, controlling, and/or maintaining, at artificial and non-competitive levels, the prices at which Fuel Injection Systems were sold, distributed, or obtained in Vermont.

**REDACTED**

(b) Defendants deliberately failed to disclose material facts to Plaintiffs and members of the Damages Class concerning their unlawful activities and artificially inflated prices for Fuel Injection Systems. Defendants owed a duty to disclose such facts, and considering the relative lack of sophistication of the average, non-business purchaser, Defendants breached that duty by their silence. Defendants misrepresented to all purchasers during the Class Period that their Fuel Injection System prices were competitive and fair.

(c) Defendants' unlawful conduct had the following effects: (1) Fuel Injection Systems price competition was restrained, suppressed, and eliminated throughout Vermont; (2) Fuel Injection Systems prices were raised, fixed, maintained, and stabilized at artificially high levels throughout Vermont; (3) Plaintiffs and members of the Damages Class were deprived of free and open competition; and (4) Plaintiffs and members of the Damages Class paid supra-competitive, artificially inflated prices for Fuel Injection Systems.

(d) As a direct and proximate result of Defendants' violations of law, Plaintiffs and members of the Damages Class suffered an ascertainable loss of money or property as a result of Defendants' use or employment of unconscionable and deceptive commercial practices as set forth above. That loss was caused by the Defendants' willful and deceptive conduct, as described herein.

(e) Defendants' deception, including their omissions concerning the price of Fuel Injection Systems, likely misled all purchasers acting reasonably under the circumstances to believe that they were purchasing Fuel Injection Systems at prices born by a free and fair market. Defendants' misleading conduct and

**REDACTED**

unconscionable activities constitutes unfair competition or unfair or deceptive acts or practices in violation of 9 Vermont § 2451, *et seq.*, and, accordingly, Plaintiffs and members of the Damages Class seek all relief available under that statute.

**FOURTH CLAIM FOR RELIEF**  
**Unjust Enrichment**  
**(on behalf of Plaintiffs and the Damages Class)**

306. Plaintiffs incorporate and reallege, as though fully set forth herein, each and every allegation set forth in the preceding paragraphs of this Complaint.

307. Plaintiffs bring this claim under the laws of all states listed in the Second and Third Claims, *supra*.

308. As a result of their unlawful conduct described above, Defendants have and will continue to be unjustly enriched. Defendants have been unjustly enriched by the receipt of, at a minimum, unlawfully inflated prices and unlawful profits on sales of Fuel Injection Systems.

309. Defendants have benefited from their unlawful acts and it would be inequitable for Defendants to be permitted to retain any of the ill-gotten gains resulting from the overpayments made by Plaintiffs of the members of the Damages Class for Fuel Injection Systems.

310. Plaintiffs and the members of the Damages Class are entitled to the amount of Defendants' ill-gotten gains resulting from their unlawful, unjust, and inequitable conduct. Plaintiffs and the members of the Damages Class are entitled to the establishment of a constructive trust consisting of all ill-gotten gains from which Plaintiffs and the members of the Damages Class may make claims on a pro rata basis.

311. Pursuit of any remedies against the firms from which Plaintiffs and the members of the Damages Class purchased vehicles containing Fuel Injection Systems subject to

**REDACTED**

Defendants' conspiracy would have been futile, given that those firms did not take part in Defendants' conspiracy.

**PRAYER FOR RELIEF**

Accordingly, Plaintiffs respectfully request that:

312. The Court determine that this action may be maintained as a class action under Rule 23(a), (b)(2) and (b)(3) of the Federal Rules of Civil Procedure, and direct that reasonable notice of this action, as provided by Rule 23(c)(2) of the Federal Rules of Civil Procedure, be given to each and every member of the Classes;

313. That the unlawful conduct, contract, conspiracy, or combination alleged herein be adjudged and decreed:

- (a) An unreasonable restraint of trade or commerce in violation of Section 1 of the Sherman Act;
- (b) A *per se* violation of Section 1 of the Sherman Act; and
- (c) An unlawful combination, trust, agreement, understanding and/or concert of action in violation of the state antitrust and unfair competition and consumer protection laws as set forth herein.
- (d) Acts of unjust enrichment by Defendants as set forth herein.

314. Plaintiffs and the members of the Damages Class recover damages, to the maximum extent allowed under such laws, and that a joint and several judgment in favor of Plaintiffs and the members of the Damages Class be entered against Defendants in an amount to be trebled to the extent such laws permit;

**REDACTED**

315. Plaintiffs and the members of the Damages Class recover damages, to the maximum extent allowed by such laws, in the form of restitution and/or disgorgement of profits unlawfully gained from them;

316. Defendants, their affiliates, successors, transferees, assignees and other officers, directors, partners, agents and employees thereof, and all other persons acting or claiming to act on their behalf or in concert with them, be permanently enjoined and restrained from in any manner continuing, maintaining or renewing the conduct, contract, conspiracy, or combination alleged herein, or from entering into any other contract, conspiracy, or combination having a similar purpose or effect, and from adopting or following any practice, plan, program, or device having a similar purpose or effect;

317. Plaintiffs and the members of the Damages Class be awarded restitution, including disgorgement of profits Defendants obtained as a result of their acts of unfair competition and acts of unjust enrichment;

318. Plaintiffs and the members of the Classes be awarded pre- and post- judgment interest as provided by law, and that such interest be awarded at the highest legal rate from and after the date of service of this Complaint;

319. Plaintiffs and the members of the Classes recover their costs of suit, including reasonable attorneys' fees, as provided by law; and

320. Plaintiffs and members of the Classes have such other and further relief as the case may require and the Court may deem just and proper.

DATED: January 16, 2015

**THE MILLER LAW FIRM, P.C.**  
By /s/ E. Powell Miller  
E. Powell Miller (P39487)

**REDACTED**

Adam T. Schnatz (P72049)  
950 W. University Dr., Ste. 300  
Rochester, Michigan 48307  
Telephone: (248) 841-2200  
Facsimile: (248) 652-2852  
epm@millerlawpc.com  
ats@millerlawpc.com

*Attorneys for Plaintiffs and Interim Liaison  
Counsel for the Proposed End-Payor Plaintiffs  
Classes*

Hollis Salzman  
Bernard Persky  
William V. Reiss  
**ROBINS, KAPLAN, MILLER & CIRESI  
L.L.P.**  
601 Lexington Avenue, Suite 3400  
New York, NY 10022  
Telephone: (212) 980-7400  
Facsimile: (212) 980-7499  
hsalzman@rkmc.com  
bpersky@rkmc.com  
wvreiss@rkmc.com

Marc M. Seltzer  
Steven G. Sklaver  
**SUSMAN GODFREY L.L.P.**  
1901 Avenue of the Stars, Suite 950  
Los Angeles, CA 90067-6029  
Telephone: (310) 789-3100  
Facsimile: (310) 789-3150  
mseltzer@susmangodfrey.com  
ssklaver@susmangodfrey.com

Terrell W. Oxford  
Warren T. Burns  
**SUSMAN GODFREY L.L.P.**  
901 Main Street, Suite 5100  
Dallas, Texas 75202  
Telephone: (214) 754-1900  
Facsimile: (214)754-1933  
toxford@susmangodfrey.com  
wburns@susmangodfrey.com

**REDACTED**

Frank C. Damrell  
Steven N. Williams  
Adam J. Zapala  
Elizabeth Tran  
**COTCHETT, PITRE &  
McCARTHY, LLP**  
San Francisco Airport Office Center  
840 Malcolm Road, Suite 200  
Burlingame, CA 94010  
Telephone: (650) 697-6000  
Facsimile: (650) 697-0577  
fdamrell@cpmlegal.com  
swilliams@cpmlegal.com  
azapala@cpmlegal.com  
etran@cpmlegal.com

*Attorneys for Plaintiffs and Interim Co-Lead  
Class Counsel for the Proposed End-Payor  
Plaintiffs Classes*

**REDACTED**

**JURY DEMAND**

Plaintiffs demand a trial by jury, pursuant to Rule 38(b) of the Federal Rules of Civil Procedure, of all issues so triable.

DATED: January 16, 2015

**THE MILLER LAW FIRM, P.C.**

By /s/ E. Powell Miller  
E. Powell Miller (P39487)  
Adam T. Schnatz (P72049)  
950 W. University Dr., Ste. 300  
Rochester, Michigan 48307  
Telephone: (248) 841-2200  
Facsimile: (248) 652-2852  
epm@millerlawpc.com  
ats@millerlawpc.com

*Attorneys for Plaintiffs and Interim Liaison  
Counsel for the Proposed End-Payor Plaintiffs  
Classes*

Hollis Salzman  
Bernard Persky  
William V. Reiss  
**ROBINS, KAPLAN, MILLER & CIRESI  
L.L.P.**

601 Lexington Avenue, Suite 3400  
New York, NY 10022  
Telephone: (212) 980-7400  
Facsimile: (212) 980-7499  
hsalzman@rkmc.com  
bpersky@rkmc.com  
wvreiss@rkmc.com

Marc M. Seltzer  
Steven G. Sklaver  
**SUSMAN GODFREY L.L.P.**  
1901 Avenue of the Stars, Suite 950  
Los Angeles, CA 90067-6029  
Telephone: (310) 789-3100  
Facsimile: (310) 789-3150  
mseltzer@susmangodfrey.com  
ssklaver@susmangodfrey.com



**REDACTED**

Terrell W. Oxford  
Warren T. Burns  
**SUSMAN GODFREY L.L.P.**  
901 Main Street, Suite 5100  
Dallas, Texas 75202  
Telephone: (214) 754-1900  
Facsimile: (214)754-1933  
toxford@susmangodfrey.com  
wburns@susmangodfrey.com

Frank C. Damrell  
Steven N. Williams  
Adam J. Zapala  
Elizabeth Tran  
**COTCHETT, PITRE &  
McCARTHY, LLP**  
San Francisco Airport Office Center  
840 Malcolm Road, Suite 200  
Burlingame, CA 94010  
Telephone: (650) 697-6000  
Facsimile: (650) 697-0577  
fdamrell@cpmlegal.com  
swilliams@cpmlegal.com  
azapala@cpmlegal.com  
etran@cpmlegal.com

*Attorneys for Plaintiffs and Interim Co-Lead  
Class Counsel for the Proposed End-Payor  
Plaintiffs Classes*